



Company name: PUMPA,a.s.

Created by:

Phone:

Email: [pumpa@pumpa.cz](mailto:pumpa@pumpa.cz)

Date: 11/09/2025

Description	Value
<b>General information:</b>	
Product name:	SEG.40.12.2.50B
Product No:	<a href="#">96075905</a>
EAN number:	5700394850780
<b>Technical:</b>	
Max. flow:	4.17 l/s
Max. head:	20.7 m
Type of impeller:	GRINDER SYSTEM
Primary shaft seal:	SIC/SIC
Approvals:	PA-I
Curve tolerance:	ISO9906:2012 3B2
<b>Materials:</b>	
Pump housing:	Cast iron
	EN1561 EN-GJL-200
Impeller:	Cast iron
	EN1561 EN-GJL-200
<b>Installation:</b>	
Maximum ambient temperature:	40 °C
Maximum operating pressure:	6 bar
Flange standard:	DIN
Pipework connection:	DN 40/50
Pump outlet:	DN 40
Pressure rating:	PN 10
Maximum installation depth:	7 m
Inst dry/wet:	SUBMERGED
Auto-coupling:	96076063
<b>Liquid:</b>	
Liquid temperature range:	0 .. 40 °C
Selected liquid temperature:	20 °C
Density:	998.2 kg/m <sup>3</sup>
<b>Electrical data:</b>	
Power input - P1:	1.6 kW
Rated power - P2:	1.2 kW
Mains frequency:	50 Hz
Rated voltage:	3 x 400-415 V
Voltage tolerance:	+6/-10 %
Max starts per hour:	30
Rated current:	3 A
Starting current:	21 A
Rated current at no load:	2.1 A
Cos phi - power factor:	0.81
Cos phi - p.f. at 3/4 load:	0.72
Cos phi - p.f. at 1/2 load:	0.58
Rated speed:	2750 rpm
Moment of inertia:	0.0038 kg m <sup>2</sup>
Motor efficiency at full load:	73 %
Motor efficiency at 3/4 load:	71 %
Motor efficiency at 1/2 load:	66 %
Number of poles:	2
Start. method:	direct-on-line
Enclosure class (IEC 34-5):	IP68
Insulation class (IEC 85):	F
Explosion proof:	no
Built-in motor protection:	THERMAL SWITCH
Thermal protec:	external
Length of cable:	10 m
Cable type:	07RN8-F
Type of cable plug:	No plug

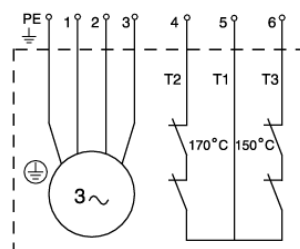
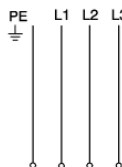
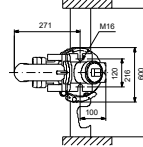
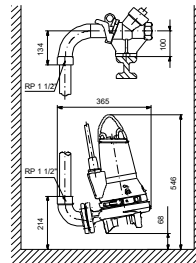
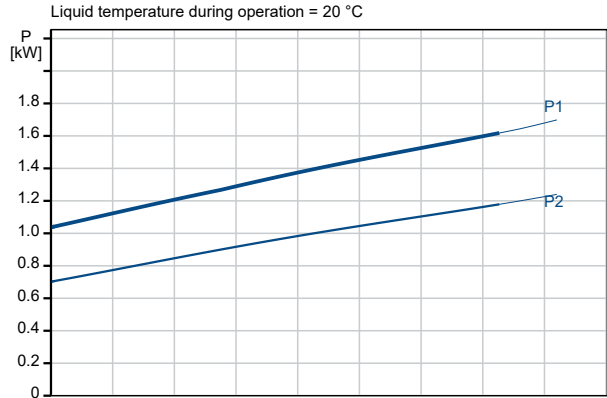
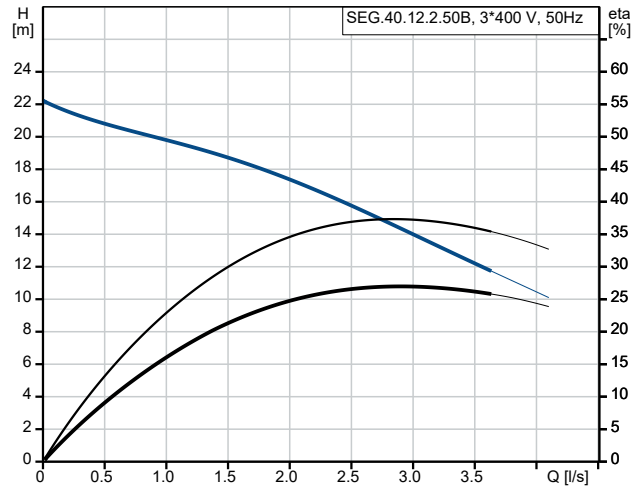



**Company name:** PUMPA,a.s.

**Created by:**

**Phone:**

**Email:** pumpa@pumpa.cz

**Date:** 11/09/2025

Description	Value
<b>Controls:</b>	
Control box:	not included
Additional I/O:	External
Moisture sensor:	without moisture sensors
AUTOADAPT:	No
<b>Others:</b>	
Net weight:	33 kg
Danish VVS No.:	391342131
Swedish RSK No.:	5885829
Finnish LVI No.:	4836103
Norwegian NRF no.:	9045801
Country of origin:	HU
Custom tariff no.:	84137021



Company name: PUMPA,a.s.

Created by:

Phone:

Email: pumpa@pumpa.cz

Date: 11/09/2025

### 96075905 SEG.40.12.2.50B 50 Hz

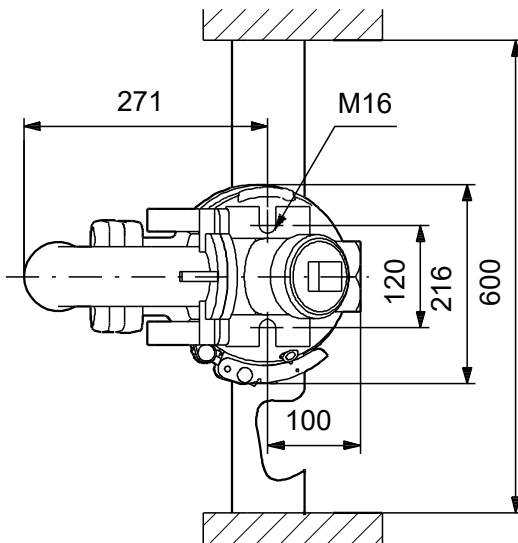
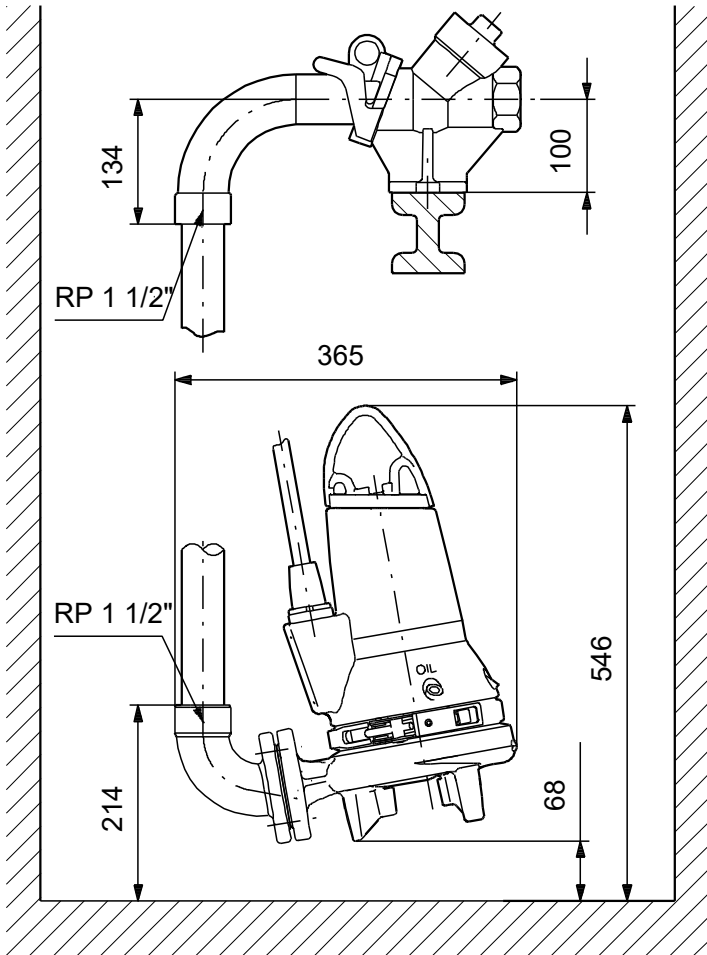

Note! All units are in [mm] unless others are stated.  
Disclaimer: This simplified dimensional drawing does not show all details.



Company name: PUMPA,a.s.

Created by:

Phone:

Email:

Date:

pumpa@pumpa.cz

11/09/2025

### 96075905 SEG.40.12.2.50B 50 Hz

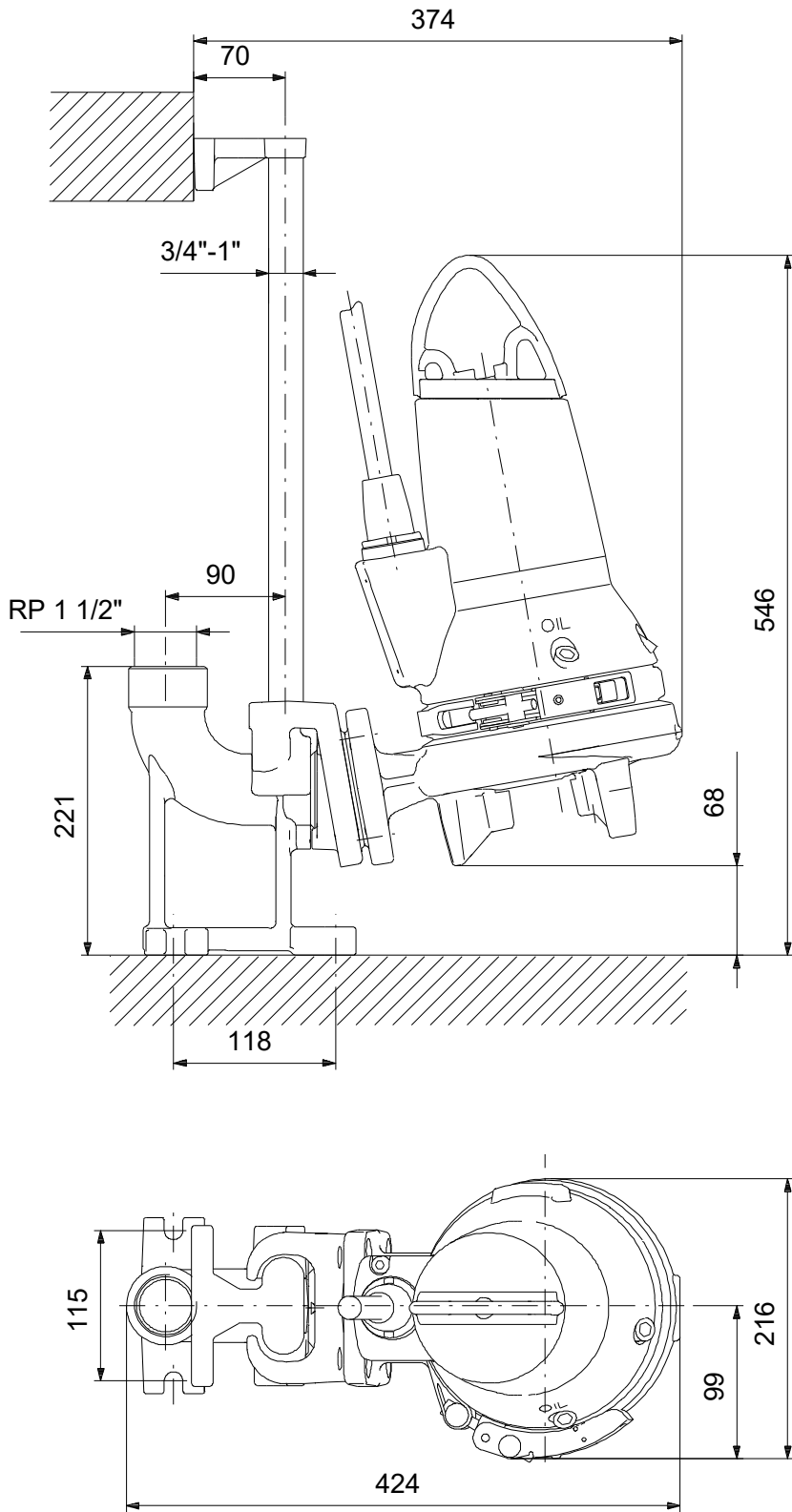

Note! All units are in [mm] unless others are stated.  
Disclaimer: This simplified dimensional drawing does not show all details.



Company name: PUMPA,a.s.

Created by:

Phone:

Email: pumpa@pumpa.cz

Date: 11/09/2025

### 96075905 SEG.40.12.2.50B 50 Hz

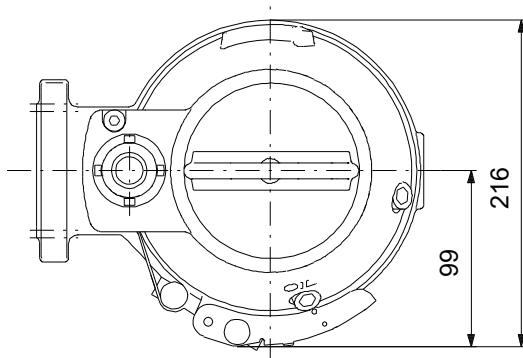
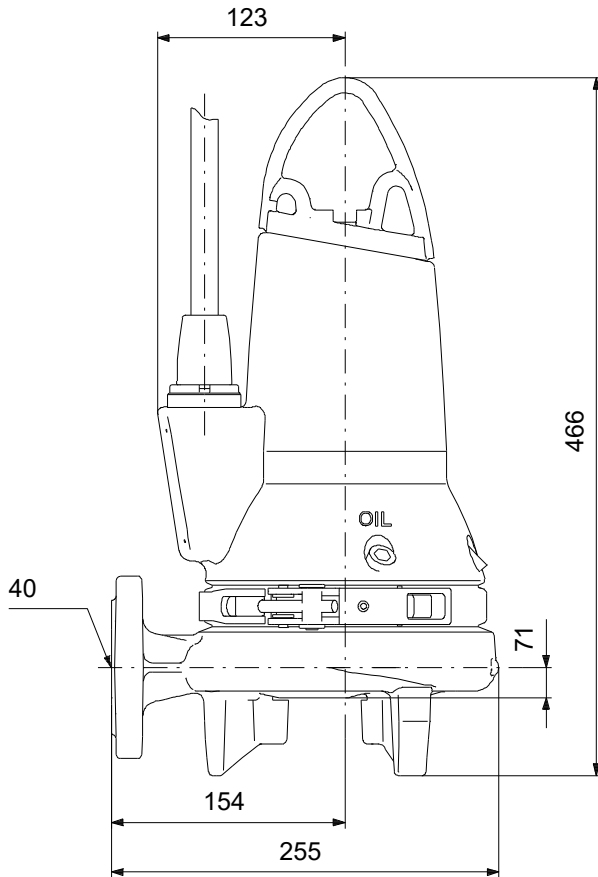

Note! All units are in [mm] unless others are stated.  
Disclaimer: This simplified dimensional drawing does not show all details.



Company name: PUMPA,a.s.

Created by:

Phone:

Email: pumpa@pumpa.cz

Date: 11/09/2025

### 96075905 SEG.40.12.2.50B 50 Hz

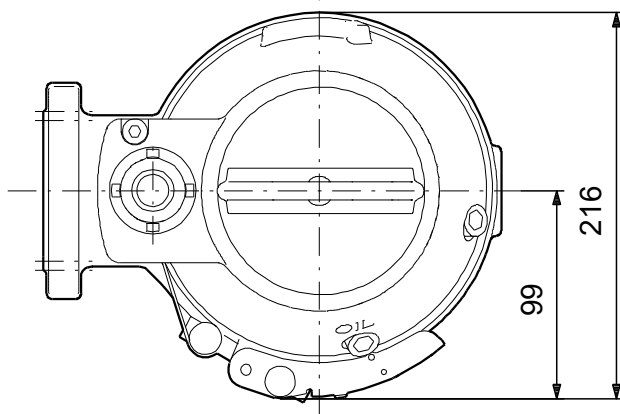
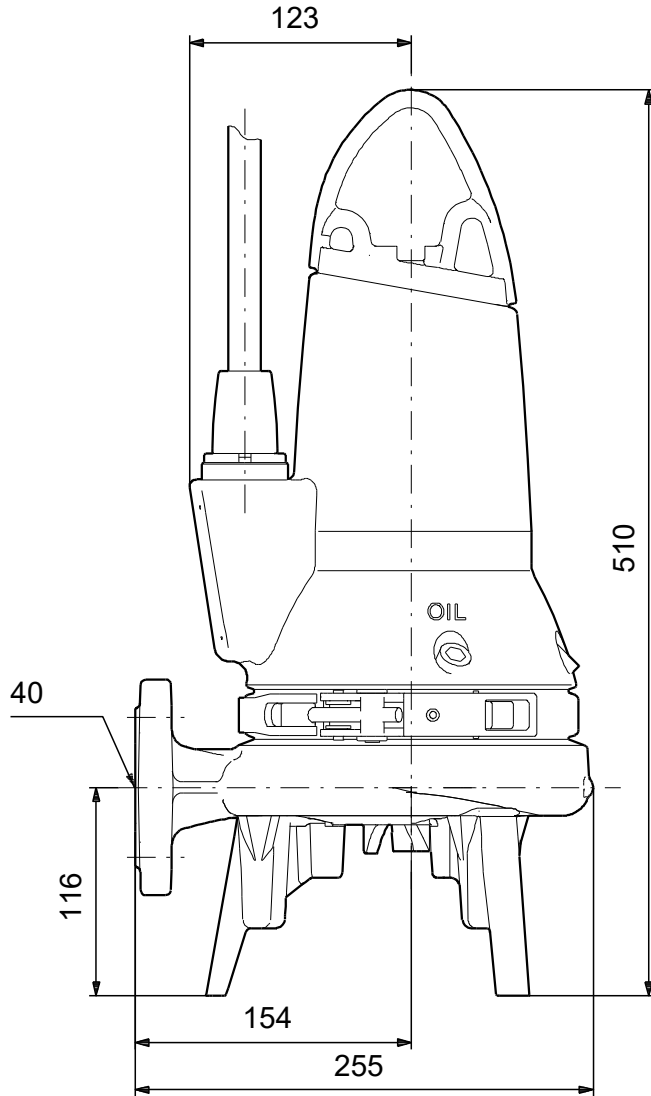

Note! All units are in [mm] unless others are stated.  
Disclaimer: This simplified dimensional drawing does not show all details.