

# PM 2

## Installation and operating instructions

GB D F I E P GR NL S FIN DK  
PL RU H RO CZ SK TR



## **(GB)** Declaration of Conformity

We **Grundfos** declare under our sole responsibility that the products **PM 2**, to which this declaration relates, are in conformity with the Council Directives on the approximation of the laws of the EC Member States relating to

- Electrical equipment designed for use within certain voltage limits (2006/95/EC).  
Standards used: EN 60730-1: 2000 and EN 60730-2-6: 2008.
- Electromagnetic compatibility (2004/108/EC).  
Standards used: EN 60730-1: 2000 and EN 60730-1, A16: 2007.

## **(F)** Déclaration de Conformité

Nous **Grundfos** déclarons sous notre seule responsabilité que les produits **PM 2** auxquels se réfère cette déclaration sont conformes aux Directives du Conseil concernant le rapprochement des législations des Etats membres CE relatives à

- Matériel électrique destiné à employer dans certaines limites de tension (2006/95/CE).  
Standards utilisés: EN 60730-1: 2000 et EN 60730-2-6: 2008.
- Compatibilité électromagnétique (2004/108/CE).  
Standards utilisés: EN 60730-1: 2000 et EN 60730-1, A16: 2007.

## **(E)** Declaración de Conformidad

Nosotros **Grundfos** declaramos bajo nuestra única responsabilidad que los productos **PM 2** a los cuales se refiere esta declaración son conformes con las Directivas del Consejo relativas a la aproximación de las legislaciones de los Estados Miembros de la CE sobre

- Material eléctrico destinado a utilizarse con determinadas límites de tensión (2006/95/CE).  
Normas aplicadas: EN 60730-1: 2000 y EN 60730-2-6: 2008.
- Compatibilidad electromagnética (2004/108/CE).  
Normas aplicadas: EN 60730-1: 2000 y EN 60730-1, A16: 2007.

## **(GR)** Δήλωση Συμμόρφωσης

Εμείς η **Grundfos** δηλώνουμε με αποκλειστικά δική μας ευθύνη ό τι τα προϊόντα **PM 2** συμμορφώνονται με την Οδηγία του Συμβουλίου επί της σύγκλισης των νόμων των Κρατών Μελών της Ευρωπαϊκής Ένωσης σε σχέση με τα

- Ηλεκτρικές συσκευές σχεδιασμένες για χρήση εντός ορισμένων ορίων ηλεκτρικής τάσης (2006/95/ΕΚ).  
Πρότυπα που χρησιμοποιήθηκαν:  
EN 60730-1: 2000 και EN 60730-2-6: 2008.
- Ηλεκτρομαγνητική συμβατότητα (2004/108/ΕΚ).  
Πρότυπα που χρησιμοποιήθηκαν: EN 60730-1: 2000 και EN 60730-1, A16: 2007.

## **(S)** Försäkran om överensstämmelse

Vi **Grundfos** försäkrar under ansvar, att produkterna **PM 2**, som omfattas av denna försäkran, är i överensstämmelse med Rådets Direktiv om inbördes närmande till EU-medlemsstaternas lagstiftning, avseende

- Elektrisk utrustning avsedd för användning inom vissa spänningsgränser (2006/95/EC).  
Använda standarder: EN 60730-1: 2000 och EN 60730-2-6: 2008.
- Elektromagnetisk kompatibilitet (2004/108/EC).  
Använda standarder: EN 60730-1: 2000 och EN 60730-1, A16: 2007.

## **(DK)** Overensstemmelseserklæring

Vi **Grundfos** erklærer under ansvar at produkterne **PM 2** som denne erklæring omhandler, er i overensstemmelse med Rådets direktiver om indbyrdes tilnærmelse til EF medlemsstaternes lovgivning om

- Elektrisk materiel bestemt til anvendelse inden for visse spændingsgrænser (2006/95/EF).  
Anvendte standarder: EN 60730-1: 2000 og EN 60730-2-6: 2008.
- Elektromagnetisk kompatibilitet (2004/108/EF).  
Anvendte standarder: EN 60730-1: 2000 og EN 60730-1, A16: 2007.

## **(D)** Konformitätserklärung

Wir **Grundfos** erklären in alleiniger Verantwortung, dass die Produkte **PM 2**, auf die sich diese Erklärung bezieht, mit den folgenden Richtlinien des Rates zur Angleichung der Rechtsvorschriften der EG-Mitgliedstaaten übereinstimmen

- Elektrische Betriebsmittel zur Verwendung innerhalb bestimmter Spannungsgrenzen (2006/95/EG).  
Normen, die verwendet wurden:  
EN 60730-1: 2000 und EN 60730-2-6: 2008.
- Elektromagnetische Verträglichkeit (2004/108/EG).  
Normen, die verwendet wurden: EN 60730-1: 2000 und EN 60730-1, A16: 2007.

## **(I)** Dichiarazione di Conformità

Noi **Grundfos** dichiariamo sotto la nostra esclusiva responsabilità che i prodotti **PM 2** ai quali questa dichiarazione si riferisce sono conformi alle Direttive del Consiglio concernente il ravvicinamento delle legislazioni degli Stati membri CE relative a

- Materiale elettrico destinato ad essere utilizzato entro certi limiti di tensione (2006/95/CE).  
Standard usati: EN 60730-1: 2000 e EN 60730-2-6: 2008.
- Compatibilità elettromagnetica (2004/108/CE).  
Standard usati: EN 60730-1: 2000 e EN 60730-1, A16: 2007.

## **(P)** Declaração de Conformidade

Nós **Grundfos** declaramos sob nossa única responsabilidade que os produtos **PM 2** aos quais se refere esta declaração estão em conformidade com as Directivas do Conselho das Comunidades Europeias relativas à aproximação das legislações dos Estados Membros respeitantes à

- Material eléctrico destinado a ser utilizado dentro de certos limites de tensão (2006/95/CE).  
Normas utilizadas: EN 60730-1: 2000 e EN 60730-2-6: 2008.
- Compatibilidade electromagnética (2004/108/CE).  
Normas utilizadas: EN 60730-1: 2000 e EN 60730-1, A16: 2007.

## **(NL)** Overeenkomstigheidsverklaring

Wij **Grundfos** verklaren geheel onder eigen verantwoordelijkheid dat de producten **PM 2** waarop deze verklaring betrekking heeft in overeenstemming zijn met de Richtlijnen van de Raad inzake de onderlinge aanpassing van de wetgevingen van de Lid-Statens betreffende

- Elektrisch materiaal bestemd voor gebruik binnen bepaalde spanningsgrenzen (2006/95/EG).  
Normen: EN 60730-1: 2000 en EN 60730-2-6: 2008.
- Elektromagnetische compatibiliteit (2004/108/EG).  
Normen: EN 60730-1: 2000 en EN 60730-1, A16: 2007.

## **(FIN)** Vastaavuusvakuutus

Me **Grundfos** vakuutamme yksin vastuullisesti, että tuotteet **PM 2**, jota tämä vakuutus koskee, noudattavat direktiivejä jotka käsittelevät EY:n jäsenvaltioiden koneellisia laitteita koskevien lakien yhdenmukaisuutta seur.:

- Määrättyjen jänniterajoitusten puitteissa käytettävät sähköiset laitteet (2006/95/EY).  
Käytetyt standardit: EN 60730-1: 2000 ja EN 60730-2-6: 2008.
- Elektromagneettinen vastaavuus (2004/108/EY).  
Käytetyt standardit: EN 60730-1: 2000 ja EN 60730-1, A16: 2007.

## **(PL)** Deklaracja zgodności

My, **Grundfos**, oświadczamy z pełną odpowiedzialnością, że nasze wyroby **PM 2**, których deklaracja niniejsza dotyczy, są zgodne z następującymi wytycznymi Rady d/s ujednoczenia przepisów prawnych krajów członkowskich EG:

- wyposażenie elektryczne do stosowania w określonym zakresie napięć (2006/95/EG).
- zastosowane normy: EN 60730-1: 2000 i EN 60730-2-6: 2008.
- zgodność elektromagnetyczna (2004/108/EG).
- zastosowane normy: EN 60730-1: 2000 i EN 60730-1, A16: 2007.

## **RU) Декларация о соответствии**

Мы, компания **Grundfos**, со всей ответственностью заявляем, что изделия **PM 2**, к которым и относится данная декларация, отвечают требованиям следующих указаний Совета ЕС об унификации законодательных предписаний стран-членов ЕС:

- Электрические машины для эксплуатации в пределах определенного диапазона значений напряжения (2006/95/EC). Применявшиеся стандарты: Евростандарт: EN 60730-1: 2000 и EN 60730-2-6: 2008.
- Электромагнитная совместимость (2004/108/EC). Применявшиеся стандарты: Евростандарт: EN 60730-1: 2000 и EN 60730-1, A16: 2007.

## **RO) Declarație de conformitate**

Noi, **Grundfos**, declarăm asumându-ne întreaga responsabilitate că produsele **PM 2** la care se referă această declarație sunt în conformitate cu Directivele Consiliului în ceea ce privește alinierea legislațiilor Statelor Membre ale CE, referitoare la:

- Echipamente electrice destinate utilizării între limite exacte de tensiune (2006/95/EC). Standarde aplicate: EN 60730-1: 2000 și EN 60730-2-6: 2008.
- Compatibilitate electromagnetică (2004/108/EC). Standarde aplicate: EN 60730-1: 2000 și EN 60730-1, A16: 2007.

## **SK) Prehlásenie o konformite**

My firma **Grundfos**, na svoju plnú zodpovednosť prehlasujeme, že výrobky **PM 2**, na ktoré sa toto prehlásenie vzťahuje, sú v súlade s nasledovnými smernicami Rady pre zblíženie právnych predpisov členských zemí Európskej únie:

- Elektrické prevádzkové prostriedky, použité v určitom napätovom rozsahu (2006/95/EG). Použité normy: EN 60730-1: 2000 a EN 60730-2-6: 2008.
- Elektromagnetická kompatibilita (2004/108/EG). Použité normy: EN 60730-1: 2000 a EN 60730-1, A16: 2007.

## **H) Konformitási nyilatkozat**

Mi, a **Grundfos**, egyedüli felelősséggel kijelentjük, hogy az **PM 2** termékek, amelyekre jelen nyilatkozat vonatkozik, megfelelnek az Európai Unió tagállamainak jogi irányelveit összehangoló tanács alábbi irányelveinek:

- Meghatározott feszültség határokon belül használt elektromos eszközök (2006/95/EK). Alkalmazott szabványok: EN 60730-1: 2000 és EN 60730-2-6: 2008.
- Elektromágneses összeférhetőség (2004/108/EK). Alkalmazott szabványok: EN 60730-1: 2000 és EN 60730-1, A16: 2007.

## **CZ) Prohlášení o shodě**

My firma **Grundfos** prohlašujeme na svou plnou odpovědnost, že výrobky **PM 2** na něž se toto prohlášení vztahuje, jsou v souladu s ustanoveními směrnice Rady pro sblížení právních předpisů členských států Evropského společenství v oblastech:

- provozování spotřebičů v toleranci napětí (2006/95/EG). použité normy: EN 60730-1: 2000 a EN 60730-2-6: 2008.
- elektromagnetická kompatibilita (2004/108/EG). použité normy: EN 60730-1: 2000 a EN 60730-1, A16: 2007.

Bjerringbro, 15th August 2008



Svend Aage Kaae  
Technical Director



# PM 2

<b>Installation and operating instructions</b>	<b>6</b>	<b>GB</b>
<b>Montage- und Betriebsanleitung</b>	<b>17</b>	<b>D</b>
<b>Notice d'installation et d'entretien</b>	<b>29</b>	<b>F</b>
<b>Istruzioni di installazione e funzionamento</b>	<b>40</b>	<b>I</b>
<b>Instrucciones de instalación y funcionamiento</b>	<b>52</b>	<b>E</b>
<b>Instruções de instalação e funcionamento</b>	<b>64</b>	<b>P</b>
<b>Οδηγίες εγκατάστασης και λειτουργίας</b>	<b>76</b>	<b>GR</b>
<b>Installatie- en bedieningsinstructies</b>	<b>88</b>	<b>NL</b>
<b>Monterings- och driftsinstruktion</b>	<b>99</b>	<b>S</b>
<b>Asennus- ja käyttöohjeet</b>	<b>108</b>	<b>FIN</b>
<b>Monterings- og driftsinstruktion</b>	<b>119</b>	<b>DK</b>
<b>Instrukcja montażu i eksploatacji</b>	<b>129</b>	<b>PL</b>
<b>Руководство по монтажу и эксплуатации</b>	<b>141</b>	<b>RU</b>
<b>Szerelési és üzemeltetési utasítás</b>	<b>153</b>	<b>H</b>
<b>Instrucțiuni de instalare și utilizare</b>	<b>165</b>	<b>RO</b>
<b>Montážní a provozní návod</b>	<b>177</b>	<b>CZ</b>
<b>Návod na montáž a prevádzku</b>	<b>188</b>	<b>SK</b>
<b>Montaj ve kullanım kılavuzu</b>	<b>199</b>	<b>TR</b>

## CONTENTS

	Page
<b>1. Symbols used in this document</b>	<b>6</b>
<b>2. Applications</b>	<b>6</b>
2.1 Liquids	6
2.2 Liquid temperature	6
2.3 Operating pressure	6
<b>3. Installation</b>	<b>6</b>
3.1 Location	7
<b>4. Electrical connection</b>	<b>8</b>
4.1 Connecting units with cable and plug fitted	8
4.2 Connecting units with no cable and plug fitted	8
4.3 Alternative power supply	8
<b>5. Control panel</b>	<b>9</b>
5.1 DIP switches	10
5.2 Enabling the DIP switch settings	11
5.3 Checking the DIP switch settings	11
<b>6. Start-up</b>	<b>11</b>
<b>7. Operation</b>	<b>11</b>
7.1 Start/stop according to water consumption	11
7.2 Start/stop with 1 bar differential pressure	11
7.3 Power supply failure	12
<b>8. Functions</b>	<b>12</b>
8.1 Auto-reset	12
8.2 Anti-cycling	12
8.3 Maximum continuous operating time (30 minutes)	12
8.4 Dry-running protection	12
<b>9. Frost protection</b>	<b>13</b>
<b>10. List of alarms</b>	<b>13</b>
<b>11. Technical data</b>	<b>14</b>
<b>12. Fault finding chart</b>	<b>15</b>
<b>13. Further product information</b>	<b>16</b>
<b>14. Disposal</b>	<b>16</b>



### Warning

*Prior to installation, read these installation and operating instructions. Installation and operation must comply with local regulations and accepted codes of good practice.*

## 1. Symbols used in this document



### Warning

*If these safety instructions are not observed, it may result in personal injury!*



### Caution

*If these safety instructions are not observed, it may result in malfunction or damage to the equipment!*



### Note

*Notes or instructions that make the job easier and ensure safe operation.*

## 2. Applications

The Grundfos PM 2 is designed for automatic start/stop control of Grundfos pumps and other pumps for water supply. The PM 2 can be installed in systems with or without a pressure tank.

Typical applications are water supply systems and rainwater systems in

- single-family houses
- blocks of flats
- summer houses and holiday cottages
- horticulture and gardening
- agriculture.

### 2.1 Liquids

Clean, thin, non-aggressive and non-explosive liquids without solid particles or fibres that may attack the unit mechanically or chemically.

Examples:

- drinking water
- rainwater.

### 2.2 Liquid temperature

0 °C - see nameplate.

### 2.3 Operating pressure

Max. 10 bar.

## 3. Installation

Install the unit on the discharge side of the pump. See fig. 2.

If pumping from a well, borehole or similar, always fit a non-return valve on the suction pipe of the pump.

It is recommended to connect the unit to the piping system using unions.

The outlet connection of the unit can be rotated 360°. See fig. 1.

The inlet connection is an integrated part of the unit housing.

The unit has a built-in non-return valve.

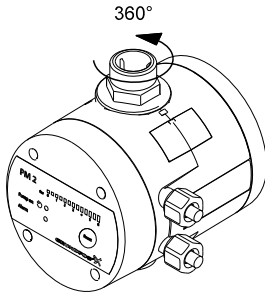

Fig. 1 Rotary outlet connection

### 3.1 Location

The installation location must be clean and well ventilated.

The PM 2 must be positioned so that it is protected from rain and direct sunlight.

The PM 2 can be installed in systems with or without a pressure tank. See fig. 2.

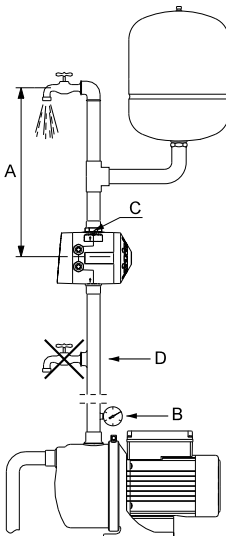

Fig. 2 Installation example

The unit can be fitted directly to the pump discharge port or between the pump and the first tapping point.

TM03 9707 1508

TM04 0336 1508

#### Pos. A in fig. 2:

It is recommended to install the unit so that the height between the unit and the highest tapping point does not exceed the values in the table below.

Start pressure set [bar]	Maximum height [m]
1.5*	11
2.0	16
2.5	21
3.0	26
3.5	31
4.0	36
4.5	41
5.0	46

\* Default setting.  
See section 7.1 Start/stop according to water consumption.

#### Pos. B in fig. 2:

To achieve correct operation, the pump should at least be able to provide the discharge pressures in the table below.

#### Minimum discharge pressure

Start pressure set	Operating mode	
	Start/stop according to water consumption*	Start/stop with 1 bar differential pressure**
[bar]	[bar]	[bar]
1.5*	1.9	2.9
2.0	2.4	3.4
2.5	2.9	3.9
3.0	3.4	4.4
3.5	3.9	4.9
4.0	4.4	5.4
4.5	4.9	5.9
5.0	5.4	6.4

\* Default setting.  
See section 7.1 Start/stop according to water consumption.

\*\* See section 7.2 Start/stop with 1 bar differential pressure.

**Pos. C in fig. 2:**

The unit should be installed so that the control panel is visible and easily accessible. Ensure that the inlet and outlet are connected correctly.

**Caution**

*To prevent water from entering the unit, do not install the unit so that the cable connections are pointing upwards. See fig. 3.*

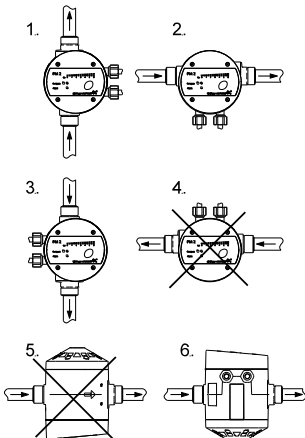
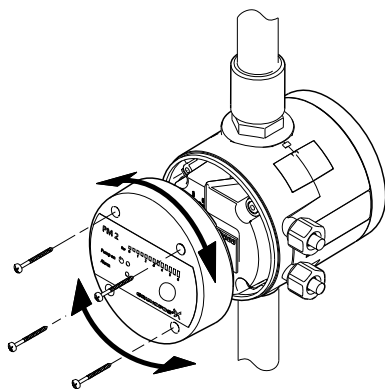

**Fig. 3** Mounting positions

**Caution**

*Mounting position 6 should be avoided if the pumped liquid contains particles as these may settle inside the internal pressure tank of the unit.*

It is possible to loosen the control panel and change its position, depending on the mounting position of the unit. See fig. 4.



**Fig. 4** Orientation of the control panel

**Pos. D in fig. 2:**

No taps must be installed between the pump and the unit.

**4. Electrical connection**

**Warning**

*The electrical connection must be carried out in accordance with local regulations and standards.*

*Before making any connections in the unit, make sure that the power supply has been switched off and that it cannot be accidentally switched on.*



*The unit must be connected to an external mains switch with a contact gap of at least 3 mm in all poles.*

*As a precaution, the unit must be connected to a socket with earth connection.*

*It is recommended to fit the permanent installation with an earth leakage circuit breaker (ELCB) with a tripping current < 30 mA.*

**4.1 Connecting units with cable and plug fitted**

Connect the unit using the supplied cable.

**4.2 Connecting units with no cable and plug fitted**

1. Remove the control panel of the unit.
2. Carry out the electrical connection as shown in fig. A or B, page 212, depending on motor type.
3. Fit the control panel securely with all four mounting screws so that enclosure class IP65 is maintained.

**4.3 Alternative power supply**

The PM 2 can be powered by a generator or other alternative power supplies, provided that the requirements for the power supply are fulfilled. See section 11. *Technical data.*

TM04 1950 1708

TM04 1951 1508



## 5. Control panel

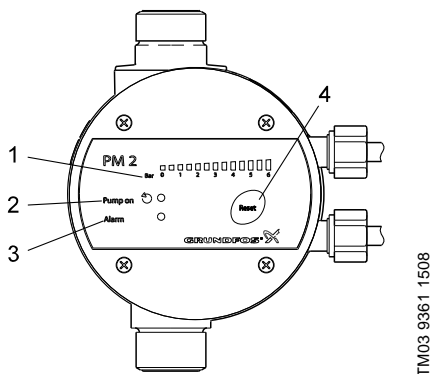

TM03 9361 1508

Fig. 5 Control panel

Pos.	Description	Function
1	"Pressure scale"	The pressure scale has 13 light fields indicating the pressure from 0 to 6 bar. All light fields illuminate briefly when the power supply is switched on.
2	"Pump on"	The green indicator light is permanently on when the pump is running. The indicator light also illuminates briefly when the power supply is switched on.
3	"Alarm"	The red indicator light is permanently on or flashes when the pump has stopped due to an operating fault. See section 12. <i>Fault finding chart</i> . The indicator light also illuminates briefly when the power supply is switched on.
4	[Reset]	The button is used for <ul style="list-style-type: none"> <li>resetting of fault indications</li> <li>checking of DIP switch settings.</li> </ul> See section 5.3 <i>Checking the DIP switch settings</i> .

## 5.1 DIP switches

The PM 2 has a number of settings which can be made with the DIP switches behind the control panel. See fig. 6.



Fig. 6 DIP switches

DIP switch		Description	Default setting
No.	Name		
1-4	START	<p><b>Start pressure (<math>p_{start}</math>)</b>            With these DIP switches the start pressure can be set from 1.5 to 5.0 bar in steps of 0.5 bar.</p> <p><b>Example:</b>            DIP switch 1 = "ON"            DIP switch 2 = "ON"            Start pressure = 1.5 + 0.5 + 1 = <b>3 bar</b>            See section 7.2.1 <i>Starting and stopping conditions</i>.</p>	All set to OFF ( $p_{start} = 1.5$ bar)
5	STOP = START + 1 BAR	<p><b>Start/stop with 1 bar differential pressure</b>            (This operating mode is only suitable for systems with a pressure tank).            When the DIP switch has been set to "ON", the pump stop pressure will be equal to <math>p_{start} + 1</math> bar. See section 7.2 <i>Start/stop with 1 bar differential pressure</i>.            In systems without a pressure tank, the DIP switch must be set to "OFF".</p>	OFF (start/stop according to water consumption)
6	AUTO RESET	<p><b>Automatic resetting of alarms</b>            When the DIP switch has been set to "ON", the cycling and dry-running alarms will automatically be reset if they have been activated. See section 8.1 <i>Auto-reset</i>.</p>	OFF (manual resetting)
7	ANTI CYCLING	<p><b>Anti-cycling</b>            When the DIP switch has been set to "ON", the pump will be stopped in case of cycling. See section 8.2 <i>Anti-cycling</i>.</p>	OFF
8	MAX RUN 30 MIN.	<p><b>Maximum continuous operating time (30 minutes)</b>            When the DIP switch has been set to "ON", the pump will automatically be stopped if it has been running continuously for 30 minutes. See section 8.3 <i>Maximum continuous operating time (30 minutes)</i>.</p>	OFF

## 5.2 Enabling the DIP switch settings

**Note** *When the desired DIP switch settings have been made, they must be enabled, otherwise the PM 2 cannot detect the settings.*

To enable the DIP switch settings, press [Reset] or disconnect and reconnect the power supply to the unit.

## 5.3 Checking the DIP switch settings

When [Reset] is kept pressed for at least 3 seconds, the light fields for the DIP switches set to "ON" will illuminate in the pressure scale.

The light fields illuminate from right to left. This means that if the light field to the far right is on, DIP switch 8 has been set to "ON", etc. See the table below.

Light field [bar]	2.5	3.0	3.5	4.0	4.5	5.0	5.5	6.0
DIP switch no.	1	2	3	4	5	6	7	8

## 6. Start-up

1. Open a tap in the system.
2. Switch on the power supply.
3. Check that the "Pump on" and "Alarm" indicator lights as well as all the green light fields in the pressure scale illuminate briefly.
  - The pump is running, and a pressure will be built up in the system. The pressure is indicated by the light fields in the pressure scale.
4. Close the tap.
5. Check that the pump stops after a few seconds and that the "Pump on" indicator light goes out.

The system is now ready for operation.

***If a pressure is not built up in the system within 5 minutes after start-up, the dry-running protection will be activated, and the pump is stopped. Check the priming conditions of the pump before attempting to restart the pump.***

**Note**

***The pump is restarted automatically if DIP switch 6 (AUTO RESET) has been set to "ON", otherwise the pump can be restarted manually by pressing [Reset].***

## 7. Operation

The PM 2 automatically starts and stops the pump. This can be achieved in two different ways:

- On delivery, the unit has a default setting which can be used in systems with or without a pressure tank. See section 7.1 *Start/stop according to water consumption*.
- In systems with a pressure tank, it is possible to use the setting described in section 7.2 *Start/stop with 1 bar differential pressure*. This setting will reduce the pump operating time.

### 7.1 Start/stop according to water consumption

As default, the PM 2 is set to this operating mode, i.e. DIP switch 5 set to "OFF".

**Caution** *With the default setting the pump will not stop until it reaches its maximum pressure.*

#### 7.1.1 Starting and stopping conditions

##### Starting conditions

The unit starts the pump when at least one of the following conditions is fulfilled:

- The flow is higher than  $Q_{min}$ .
- The pressure is lower than  $p_{start}$ . The default start pressure is 1.5 bar and can be increased in steps of 0.5 bar. See section 5.1 *DIP switches*.

##### Stopping conditions

The unit stops the pump with a time delay of 10 seconds when the following conditions are both fulfilled:

- The flow is lower than  $Q_{min}$ .
- The pressure is higher than  $p_{start}$ .

The  $p_{start}$  and  $Q_{min}$  values are shown in section 11. *Technical data*.

### 7.2 Start/stop with 1 bar differential pressure

This operating mode can be used in systems with a pressure tank of a sufficient size.

In this operating mode, the pump is started and stopped at a 1 bar differential pressure, which reduces the pump operating time. If the pressure tank is of an insufficient size, it will cause cycling of the pump.

To enable this operating mode, set DIP switch 5 to "ON". See section 5.1 *DIP switches*.

### 7.2.1 Starting and stopping conditions

The conditions described below require that DIP switch 5 has been set to "ON".

#### Starting conditions

The unit starts the pump when the pressure is lower than  $p_{\text{start}}$ .

The default start pressure is 1.5 bar and can be increased in steps of 0.5 bar. See section 5.1 *DIP switches*.

#### Stopping conditions

The unit stops the pump when the pressure is higher than  $p_{\text{stop}}$ .

$p_{\text{stop}} = p_{\text{start}} + 1$  bar.

### 7.3 Power supply failure

In case of a power supply failure, the pump restarts automatically when power returns and runs for at least 10 seconds.

## 8. Functions

### 8.1 Auto-reset

When the auto-reset function is enabled, cycling and dry-running alarms will be automatically reset.

To enable the function, set DIP switch 6 to "ON".

See section 5.1 *DIP switches*.

***The auto-reset function should NOT be enabled on pumps which cannot self-prime when water returns after dry-running.***

Caution

### 8.2 Anti-cycling

To avoid inadvertent starts and stops of the pump in case of a failure in the installation, the anti-cycling function can be enabled.

The function will detect cycling if it occurs and stop the pump with an alarm.

When the PM 2 has been set to start/stop according to water consumption, cycling may occur in the following situations:

- In case of a minor leakage.
- If a tap has not been entirely closed.

When the PM 2 has been set to start/stop with 1 bar differential pressure, cycling may occur in the following situations:

- If the pressure tank has lost its precharge pressure.
- If the size of the pressure tank is insufficient.

If the cycling alarm has been activated, the pump can be restarted manually by pressing [Reset].

When the auto-reset function is enabled, the pump will be restarted automatically after 12 hours in alarm condition.

To enable the function, set DIP switch 7 to "ON".

See section 5.1 *DIP switches*.

***In case of a very small consumption, the anti-cycling function may register this as a minor leakage and stop the pump inadvertently. If this occurs, the function can be disabled.***

Note

### 8.3 Maximum continuous operating time (30 minutes)

When this function is enabled, the pump will be stopped when the pump has been running continuously for 30 minutes.

Restart the pump by pressing [Reset].

The purpose of this function is to avoid unnecessary water and current consumption, e.g. in case of pipe fracture or considerable leakages.

***When the function is enabled, any consumption exceeding 30 minutes will cause an alarm, and the pump will be stopped.***

Note

***If enabled, the auto-reset function will not restart the pump.***

To enable the function, set DIP switch 8 to "ON".

See section 5.1 *DIP switches*.

### 8.4 Dry-running protection

The unit incorporates dry-running protection that automatically stops the pump in case of dry running. The dry-running protection functions differently during priming and operation.

***If a dry-running alarm has been activated, the cause should be found before the pump is restarted in order to prevent damage to the pump.***

Caution

#### 8.4.1 Dry running during priming

If the unit detects no pressure and no flow within 5 minutes after it has been connected to a power supply and the pump has started, the dry-running alarm is activated.

#### 8.4.2 Dry running during operation

If the unit detects no pressure and no flow within 40 seconds during normal operation, the dry-running alarm is activated.

#### 8.4.3 Resetting of dry-running alarm

##### Manual resetting

If a dry-running alarm has been activated, the pump can be restarted manually by pressing [Reset]. If the unit detects no pressure and no flow within 40 seconds after restarting, the dry-running alarm is re-activated.

##### Auto-reset

When the auto-reset function is enabled, the pump will be restarted automatically after 30 minutes in alarm condition. If, after restarting, the pump has not been primed within 5 minutes of operation, the dry-running alarm will reappear. The auto-reset function will attempt to restart the pump every 30 minutes during the first 24 hours. Then there will be 24 hours between the restarting attempts.

## 9. Frost protection

If the unit is subjected to frost in periods of inactivity, the unit and the piping system should be drained before the unit is taken out of operation.

**Note** *The unit has no draining options, but mounting the unit in one of the positions shown in fig. 7 makes draining easier.*

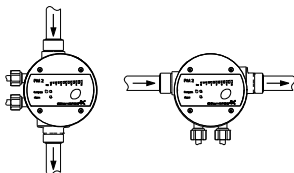

TM04 5459 3209

**Fig. 7** Mounting positions making draining easier

## 10. List of alarms

Indication	Alarm	Cause
"Alarm" is permanently on.	Dry running.	The pump has been running without water.
"Alarm" flashes once per period.	Cycling.	The pump is cycling. <b>Note:</b> Occurs only if the anti-cycling function has been enabled. See section 8.2 <i>Anti-cycling</i> .
"Alarm" flashes twice per period.	Maximum operating time.	The pump has been running continuously for 30 minutes. <b>Note:</b> Occurs only if the function "maximum continuous operating time (30 minutes)" has been enabled. See section 8.3 <i>Maximum continuous operating time (30 minutes)</i> .
"Alarm" flashes three times per period.	Protection mode.	The pump has had too many start/stop sequences within a short period. Each pump start is delayed a few seconds to protect the installation. The start delay is active until normal operation has been re-established. <b>Note:</b> The protection mode will protect the installation when the PM 2 is set to start/stop with 1 bar differential pressure, i.e. when DIP switch 5 is set to "ON". The protection mode functions independently of the anti-cycling function.
"Alarm" flashes more than three times per period.	Internal fault.	Internal fault in the unit.

## 11. Technical data

Data	230 V model	115 V model
Supply voltage	1 x 220-240 VAC	1 x 110-120 VAC
Maximum inductive contact load	10 A	
Frequency	50/60 Hz	
Maximum ambient temperature	See nameplate.	
Liquid temperature	0 °C - see nameplate.	
$p_{\text{start}}$ <sup>1)</sup>	1.5 to 5 bar	
$p_{\text{stop}}$ <sup>2)</sup>	$p_{\text{start}} + 1$ bar	
$Q_{\text{min}}$	1.0 litre/min.	
Time delay during stopping	10 seconds	
Maximum operating pressure	PN 10 / 10 bar / 1 MPa	
Enclosure class	IP65	
Volume of internal pressure tank	0.1 litre	
Dimensions	See fig. C, page 212	

<sup>1)</sup> The start pressure ( $p_{\text{start}}$ ) can be set in steps of 0.5 bar. The setting is described in section 5.1 *DIP switches*.

<sup>2)</sup> The stop pressure ( $p_{\text{stop}}$ ) is only used in systems with a pressure tank. See section 7.2 *Start/stop with 1 bar differential pressure*.

The technical data may be limited by the pump data. See installation and operating instructions for the pump.

## 12. Fault finding chart



### Warning

Before starting work on the pump/PM unit, make sure that the power supply has been switched off and that it cannot be accidentally switched on.

GB

Fault	Cause	Remedy
1. The green light field for "0 bar" is off even if the power supply has been switched on.	a) The fuses in the electric installation have blown.	Replace the fuses. If the new fuses also blow, check the electric installation.
	b) The earth leakage circuit breaker or the voltage-operated circuit breaker has been tripped out.	Cut in the circuit breaker.
	c) No power supply.	Contact the power supply authorities.
	d) The PM unit is defective.	Repair or replace the PM unit.*
2. The green "Pump on" indicator light is on, but the pump does not start.	a) The power supply to the pump is disconnected after the PM unit.	Check the plug and cable connections, and check if the built-in circuit breaker of the pump is switched off.
	b) The motor protection of the pump has tripped out due to overload.	Check if the motor/pump is blocked.
	c) The pump is defective.	Repair or replace the pump.
	d) The PM unit is defective.	Repair or replace the PM unit.*
3. The pump does not start when water is consumed. "Pump on" is off.	a) Too big difference in height between the PM unit and the tapping point.	Adjust the installation, or increase the start pressure. See section 5.1 DIP switches.
	b) The PM unit is defective.	Repair or replace the PM unit.*
4. <b>System without pressure tank:</b> Frequent starts/stops.	a) DIP switch 5 set to "ON".	Set DIP switch 5 to "OFF". See section 5.1 DIP switches.
	b) Leakage in the pipework.	Check and repair the pipework.
	c) The non-return valve is stuck in open position.	Clean or replace the non-return valve.*
5. <b>System with pressure tank:</b> Frequent starts/stops.	a) The pressure tank has no precharge pressure, or the tank size is insufficient.	Check the tank precharge pressure, and recharge the tank, if necessary. If the size of the pressure tank is insufficient, set DIP switch 5 to "OFF", or replace the pressure tank.
	b) Leaky non-return valve.	Clean or replace the non-return valve.*
6. The pump does not stop.	a) The pump cannot deliver the necessary discharge pressure.	Replace the pump.
	b) The start pressure is set too high.	Decrease the start pressure.
	c) The PM unit is defective.	Repair or replace the PM unit.*
	d) The non-return valve is stuck in open position.	Clean or replace the non-return valve.*
7. The red "Alarm" indicator light is permanently on.	a) Dry running. The pump needs water.	Check the pipework.
	b) The power supply to the pump is disconnected after the PM unit.	Check the plug and cable connections, and check if the built-in circuit breaker of the pump is switched off.
	c) The motor protection of the pump has tripped out due to overload.	Check if the motor/pump is blocked.
	d) The pump is defective.	Repair or replace the pump.
	e) The PM unit is defective.	Repair or replace the PM unit.*

Fault	Cause	Remedy
8. <b>System without pressure tank:</b> The red "Alarm" indicator light flashes once per period.	a) Cycling. A tap has not been closed entirely after use.	Check that all taps have been closed. See section 8.2 <i>Anti-cycling</i> .
	b) Cycling. There is a minor leakage in the system.	Check the system for leakages. See section 8.2 <i>Anti-cycling</i> .
9. <b>System with pressure tank:</b> The red "Alarm" indicator light flashes once per period.	a) Cycling. The pressure tank has no precharge pressure, or the tank size is insufficient.	Check the tank precharge pressure, and recharge the tank, if necessary. If the size of the pressure tank is insufficient, set DIP switch 5 to "OFF", or replace the pressure tank. See section 8.2 <i>Anti-cycling</i> .
10. The red "Alarm" indicator light flashes twice per period.	a) Maximum continuous operating time (30 minutes). The pump has been running continuously for 30 minutes.	Check the system for leakages. Disable the function to allow the pump to run for 30 minutes. See section 8.3 <i>Maximum continuous operating time (30 minutes)</i> .
11. The red "Alarm" indicator light flashes three times per period, and each pump start is delayed a few seconds.	a) Too many start/stop sequences within a short period. The pressure tank has no precharge pressure, or the tank size is insufficient.	Check the tank precharge pressure, and recharge the tank, if necessary. If the size of the pressure tank is insufficient, set DIP switch 5 to "OFF", or replace the pressure tank.
	b) Too many start/stop sequences within a short period. The PM 2 is set to start/stop with 1 bar differential pressure, i.e. DIP switch 5 is set to "ON", but no pressure tank has been installed in the system.	Set DIP switch 5 to "OFF".
12. The red "Alarm" indicator light flashes four times per period.	a) Pressure sensor fault.	Repair or replace the PM unit.*

\* See service instructions on [www.grundfos.com](http://www.grundfos.com) > International website > WebCAPS > Service.

### 13. Further product information

Further information and technical details for the Grundfos PM 2 can be found on [www.grundfos.com](http://www.grundfos.com) > International website > WebCAPS.

If you have any questions, feel free to contact the nearest Grundfos company or service workshop.

### 14. Disposal

This product or parts of it must be disposed of in an environmentally sound way:

1. Use the public or private waste collection services.
2. If this is not possible, contact the nearest Grundfos company or service workshop.



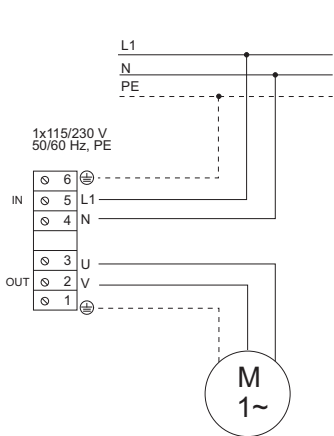

Fig. A

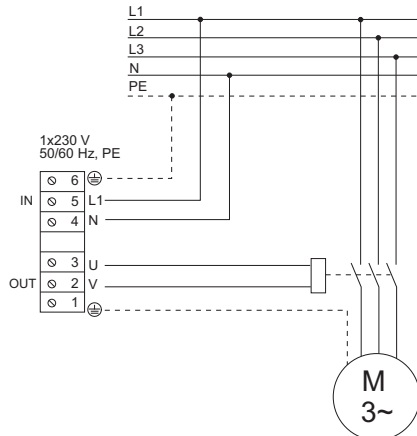

Fig. B

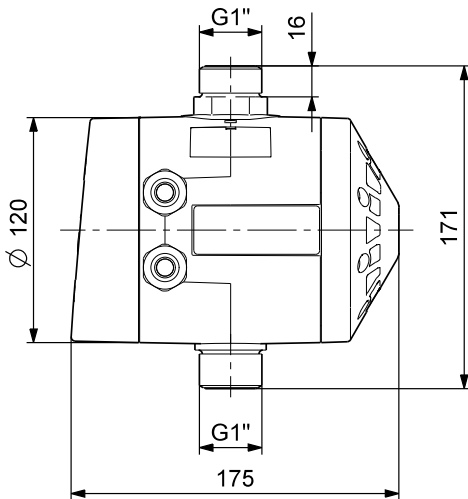
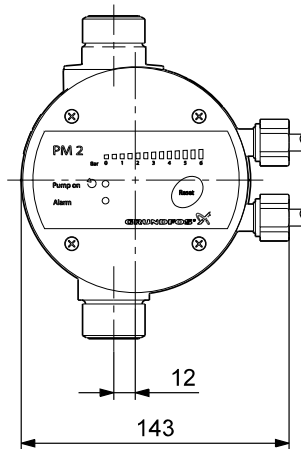

Fig. C



TM04 1991 1708

TM03 9220 3707 - TM04 1953 1508



**Argentina**

Bombas GRUNDFOS de Argentina S.A.  
Ruta Panamericana km. 37.500 Lote  
34A  
1619 - Garin  
Pcia. de Buenos Aires  
Phone: +54-3327 414 444  
Telefax: +54-3327 411 111

**Australia**

GRUNDFOS Pumps Pty. Ltd.  
P.O. Box 2040  
Regency Park  
South Australia 5942  
Phone: +61-8-8461-4611  
Telefax: +61-8-8340 0155

**Austria**

GRUNDFOS Pumpen Vertrieb  
Ges.m.b.H.  
Grundfosstraße 2  
A-5082 Grödig/Salzburg  
Tel.: +43-6246-883-0  
Telefax: +43-6246-883-30

**Belgium**

N.V. GRUNDFOS Bellux S.A.  
Boomsseemweg 81-83  
B-2630 Aartselaar  
Tel.: +32-3-870 7300  
Télécoöpie: +32-3-870 7301

**Belorussia**

Представительство ГРУНДФОС в  
Минске  
220123, Минск  
ул. Б. Хоружей, 22, оф. 1105  
Тел.: +(37517) 233 97 65,  
Факс: +(37517) 233 97 69  
E-mail: grundfos\_minsk@mail.ru

**Bosnia/Herzegovina**

GRUNDFOS Sarajevo  
Trg Heroja 16,  
BiH-71000 Sarajevo  
Phone: +387 33 713 290  
Telefax: +387 33 659 079  
e-mail: grundfos@bih.net.ba

**Brazil**

BOMBAS GRUNDFOS DO BRASIL  
Av. Humberto de Alencar Castelo  
Branco, 630  
CEP 09850 - 300  
São Bernardo do Campo - SP  
Phone: +55-11 4393 5533  
Telefax: +55-11 4343 5015

**Bulgaria**

GRUNDFOS Pumpen Vertrieb  
Representative Office - Bulgaria  
Bulgaria, 1421 Sofia  
Lozenetz District  
105-107 Arsenalski Blvd.  
Phone: +359 2963 3820, 2963 5653  
Telefax: +359 2963 1305

**Canada**

GRUNDFOS Canada Inc.  
2941 Brighton Road  
Oakville, Ontario  
L6H 6C9  
Phone: +1-905 829 9533  
Telefax: +1-905 829 9512

**China**

GRUNDFOS Pumps (Shanghai) Co. Ltd.  
51 Floor, Raffles City  
No. 266 Xi Zang Road, (M)  
Shanghai 200001  
PRC  
Phone: +86-021-612 252 22  
Telefax: +86-021-612 253 33

**Croatia**

GRUNDFOS CROATIA d.o.o.  
Cebini 37, Buzin  
HR-10010 Zagreb  
Phone: +385 1 6595 400  
Telefax: +385 1 6595 499  
www.grundfos.hr

**Czech Republic**

GRUNDFOS s.r.o.  
Čajkovského 21  
779 00 Olomouc  
Phone: +420-585-716 111  
Telefax: +420-585-716 299

**Denmark**

GRUNDFOS DK A/S  
Martin Bachs Vej 3  
DK-8850 Bjerringbro  
Tlf.: +45-87 50 50 50  
Telefax: +45-87 50 51 51  
E-mail: info\_GDK@grundfos.com  
www.grundfos.com/DK

**Estonia**

GRUNDFOS Pumps Eesti OÜ  
Peterburi tee 92G  
11415 Tallinn  
Tel.: +372 606 1690  
Fax: +372 606 1691

**Finland**

OY GRUNDFOS Pumput AB  
Mestariintie 11  
FIN-01730 Vantaa  
Phone: +358-3066 5650  
Telefax: +358-3066 5655

**France**

Pompes GRUNDFOS Distribution S.A.  
Parc d'Activités de Chesnes  
57, rue de Malacombe  
F-38290 St. Quentin Fallavier (Lyon)  
Tel.: +33-4 74 82 15 15  
Télécoöpie: +33-4 74 94 10 51

**Germany**

GRUNDFOS GMBH  
Schillerstr. 33  
40699 Erkrath  
Tel.: +49-(0) 211 929 69-0  
Telefax: +49-(0) 211 929 69-3799  
e-mail: info.service@grundfos.de  
Service in Deutschland:  
e-mail: kundendienst@grundfos.de

**Greece**

GRUNDFOS Hellas A.E.B.E.  
20th km. Athinon-Markopoulou Av.  
P.O. Box 71  
GR-19002 Peania  
Phone: +0030-210-66 83 400  
Telefax: +0030-210-66 46 273

**Hong Kong**

GRUNDFOS Pumps (Hong Kong) Ltd.  
Unit 1, Ground floor  
Siu Wai Industrial Centre  
29-33 Wing Hong Street &  
68 King Lam Street, Cheung Sha Wan  
Kowloon  
Phone: +852-27861706 / 27861741  
Telefax: +852-27586664

**Hungary**

GRUNDFOS Hungária Kft.  
Park u. 8  
H-2045 Törökbalint,  
Phone: +36-23 511 110  
Telefax: +36-23 511 111

**India**

GRUNDFOS Pumps India Private Lim-  
ited  
118 Old Mahabaliapuram Road  
Thoraipakkam  
Chennai 600 096  
Phone: +91-44 2496 6800

**Indonesia**

PT GRUNDFOS Pumps  
Jl. Rawa Sumur III, Blok III / CC-1  
Kawasan Industri, Pulogadung  
Jakarta 13930  
Phone: +62-21-460 6909  
Telefax: +62-21-460 6910 / 460 6901

**Ireland**

GRUNDFOS (Ireland) Ltd.  
Unit A, Merywell Business Park  
Ballymount Road Lower  
Dublin 12  
Phone: +353-1-4089 800  
Telefax: +353-1-4089 830

**Italy**

GRUNDFOS Pompe Italia S.r.l.  
Via Gran Sasso 4  
I-20060 Truccazzano (Milano)  
Tel.: +39-02-95838112  
Telefax: +39-02-95309290 / 95838461

**Japan**

GRUNDFOS Pumps K.K.  
Gotanda Metalton Bldg., 5F,  
5-21-15, Higashi-gotanda  
Shiagawa-ku, Tokyo  
141-0022 Japan  
Phone: +81 35 448 1391  
Telefax: +81 35 448 9619

**Korea**

GRUNDFOS Pumps Korea Ltd.  
6th Floor, Aju Building 679-5  
Yeoksam-dong, Kangnam-ku, 135-916  
Seoul, Korea  
Phone: +82-2-5317 600  
Telefax: +82-2-5633 725

**Latvia**

SIA GRUNDFOS Pumps Latvia  
Deglava biznesa centrs  
Augusta Deglava iela 60, LV-1035, Rīga,  
Tālr.: +371 714 9640, 7 149 641  
Fakss: +371 914 9646

**Lithuania**

GRUNDFOS Pumps UAB  
Smolensko g. 6  
LT-03201 Vilnius  
Tel.: +370 52 395 430  
Fax: +370 52 395 431

**Malaysia**

GRUNDFOS Pumps Sdn. Bhd.  
7 Jalan Peguam U1/25  
Glenmarie Industrial Park  
40150 Shah Alam  
Selangor  
Phone: +60-3-5569 2922  
Telefax: +60-3-5569 2866

**México**

BOMBAS GRUNDFOS de México S.A. de  
C.V.  
Boulevard TLC No. 15  
Parque Industrial Sita Aeropuerto  
Apodaca, N.L. 66600  
Phone: +52-81-8144 4000  
Telefax: +52-81-8144 4010

**Netherlands**

GRUNDFOS Netherlands  
Veluwezoom 35  
1326 AE Almere  
Postbus 22015  
1302 CA ALMERE  
Tel.: +31-88-478 6336  
Telefax: +31-88-478 6332  
e-mail: info\_qln@grundfos.com

**New Zealand**

GRUNDFOS Pumps NZ Ltd.  
17 Beatrice Tinsley Crescent  
North Harbour Industrial Estate  
Albany, Auckland  
Phone: +64-9-415 3240  
Telefax: +64-9-415 3250

**Norway**

GRUNDFOS Pumper A/S  
Strømsveien 344  
Postboks 235, Leirdal  
N-1011 Oslo  
Tlf.: +47-22 90 47 00  
Telefax: +47-22 32 21 50

**Poland**

GRUNDFOS Pompy Sp. z o.o.  
ul. Klonowa 23  
Baranowo k. Poznania  
PL-62-081 Przemierowo  
Tel: (+48-61) 650 13 00  
Fax: (+48-61) 650 13 50

**Portugal**

Bombas GRUNDFOS Portugal, S.A.  
Rua Calvet de Magalhães, 241  
Apartado 1079  
P-2770-153 Paços de Arcos  
Tel.: +351-21-440 76 00  
Telefax: +351-21-440 76 90

**România**

GRUNDFOS Pompe România SRL  
Bd. Biruintei, nr 103  
Pantelimon county Ilfov  
Phone: +40 21 200 4100  
Telefax: +40 21 200 4101  
E-mail: romania@grundfos.ro

**Russia**

ООО Грундфос  
Россия, 109544 Москва, ул. Школьная 39  
Tel. (+7) 495 737 30 00, 564 88 00  
Факс (+7) 495 737 75 36, 564 88 11  
E-mail grundfos.moscow@grundfos.com

**Serbia**

GRUNDFOS Predstavništvo Beograd  
Dr. Milutina Ivkovića 2a/29  
YU-11000 Beograd  
Phone: +381 11 26 47 877 / 11 26 47  
496  
Telefax: +381 11 26 48 340

**Singapore**

GRUNDFOS (Singapore) Pte. Ltd.  
24 Tuas West Road  
Jurong Town  
Singapore 638381  
Phone: +65-6865 1222  
Telefax: +65-6861 8402

**Slovenia**

GRUNDFOS d.o.o.  
Šlandrova 8b, SI-1231 Ljubljana-Črnuče  
Phone: +386 1 568 0610  
Telefax: +386 1 568 0619  
E-mail: slovenia@grundfos.si

**Spain**

Bombas GRUNDFOS España S.A.  
Camino de la Fuenteclilla, s/n  
E-28110 Algete (Madrid)  
Tel.: +34-91-848 8800  
Telefax: +34-91-628 0465

**Sweden**

GRUNDFOS AB  
Box 333 (Lunnagårdsgatan 6)  
431 24 Mölndal  
Tel.: +46(0)771-32 23 00  
Telefax: +46(0)31-331 94 60

**Switzerland**

GRUNDFOS Pumpen AG  
Bruggacherstrasse 10  
CH-8117 Fällanden/ZH  
Tel.: +41-1-806 8111  
Telefax: +41-1-806 8115

**Taiwan**

GRUNDFOS Pumps (Taiwan) Ltd.  
7 Floor, 219 Min-Chuan Road  
Taichung, Taiwan, R.O.C.  
Phone: +886-4-2305 0868  
Telefax: +886-4-2305 0878

**Thailand**

GRUNDFOS (Thailand) Ltd.  
92 Chaloeem Phrakiat Rama 9 Road,  
Dokmai, Pravej, Bangkok 10250  
Phone: +66-2-725 8999  
Telefax: +66-2-725 8998

**Turkey**

GRUNDFOS POMPA San. ve Tic. Ltd.  
Sti.  
Gebze Organize Sanayi Bölgesi  
Ihsan dede Caddesi,  
2. yol 200, Sokak No. 204  
41490 Gebze/Kocaeli  
Phone: +90 - 262-679 7979  
Telefax: +90 - 262-679 7805  
E-mail: satis@grundfos.com

**Ukraine**

ТОВ ГРУНДФОС УКРАЇНА  
01010 Київ, Вул. Московська 86,  
Тел.: (+38 044) 390 40 50  
Факс: (+38 044) 390 40 59  
E-mail: ukraine@grundfos.com

**United Arab Emirates**

GRUNDFOS Gulf Distribution  
P.O. Box 16768  
Jebel Ali Free Zone  
Dubai  
Phone: +971-4- 8815 166  
Telefax: +971-4-8815 136

**United Kingdom**

GRUNDFOS Pumps Ltd.  
Grovebury Road  
Leighton Buzzard/Beds. LU7 8TL  
Phone: +44-1525-850000  
Telefax: +44-1525-850011

**U.S.A.**

GRUNDFOS Pumps Corporation  
17100 West 118th Terrace  
Olathe, Kansas 66061  
Phone: +1-913-227-3400  
Telefax: +1-913-227-3500

**Usbekistan**

Представительство ГРУНДФОС в  
Ташкенте  
700000 Ташкент ул. Усмана Носира 1-й  
тулиж 5  
Телефон: (3712) 55-68-15  
Факс: (3712) 53-36-35

<b>96868505</b> 0210	<b>331</b>
Repl. 96868505 1009	

The name Grundfos, the Grundfos logo, and the payoff Be–Think–Innovate are registered trademarks owned by Grundfos Management A/S or Grundfos A/S, Denmark. All rights reserved worldwide.

---