

Operating and installation instructions

Double window sight glasses

(PN16 / 40)

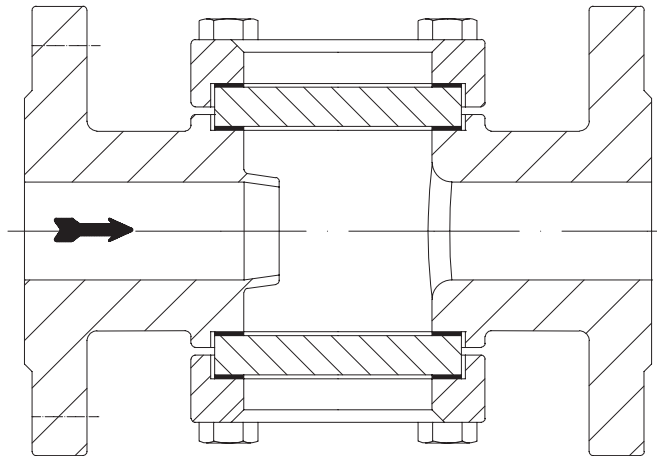

PN16 / PN40

- with flanges (BR 660/661....1)
- with screwed sockets (BR 660/661....2)
- with butt weld ends (BR 660/661....4)

Contents

1.0 General information on operating instructions.....	2	7.0 Care and maintenance.....	7
2.0 Notes on possible dangers.....	2	7.1 Tightening torques.....	7
2.1 Significance of symbols	2	8.0 Troubleshooting	7
2.2 Explanatory notes on safety information	2	9.0 Troubleshooting table	7
3.0 Storage and transport	2	10.0 Dismantling the valve or the body	8
4.0 Description.....	3	11.0 Warranty / Guarantee	8
4.1 Scope of applications	3	12.0 EC declaration of conformity	9
4.2 Operating principles	3		
4.3 Diagram.....	4		
4.4 Technical data - remarks	4		
4.5 Marking	4		
5.0 Installation.....	5		
5.1 General notes on installation.....	5		
5.2 Installation instructions for welding	6		
5.3 Installation position.....	6		
6.0 Putting the valve into operation.....	6		

1.0 General information on operating instructions

These operating instructions provide information on mounting and maintaining the fittings. Please contact the supplier or the manufacturer in case of problems which cannot be solved by reference to the operating instructions.

They are binding on the transport, storage, installation, start-up, operation, maintenance and repair.

The notes and warnings must be observed and adhered to.

- Handling and all work must be carried out by expert personnel or all activities must be supervised and checked.

It is the owner's responsibility to define areas of responsibility and competence and to monitor the personnel.

- In addition, current regional safety requirements must be applied and observed when taking the fittings out of service as well as when maintaining and repairing them.

The manufacturer reserves the right to introduce technical modifications at any time.

These Operating Instructions comply with the requirements of EU Directives.

2.0 Notes on possible dangers

2.1 Significance of symbols



Warning of general danger.

2.2 Explanatory notes on safety information

In these Operating and Installation Instructions dangers, risks and items of safety information are highlighted to attract special attention.

Information marked with the above symbol and "**ATTENTION!**" describe practices, a failure to comply with which can result in serious injury or danger of death for users or third parties or in material damage to the system or the environment. It is vital to comply with these practices and to monitor compliance.

All other information not specifically emphasised such as transport, installation, operating and maintenance instructions as well as technical data (in the operating instructions, product documentation and on the device itself) must also be complied with to the fullest extent in order to avoid faults which in turn can cause serious injury to persons or damage to property.

3.0 Storage and transport

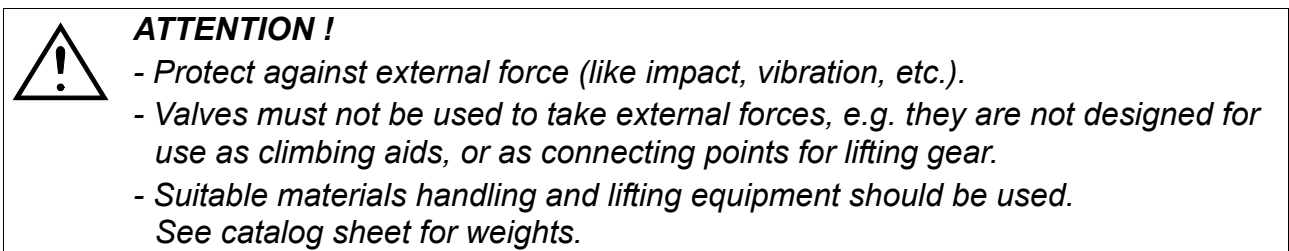

- At -20°C to +65°C.

- The paint is a base coat to protect against corrosion during transportation and storage. Do not damage paint protection.

4.0 Description

4.1 Scope of applications

Double window sight glasses are used for the checking of media flow in pipelines and the monitoring of apparatus and system function.



ATTENTION !

- Refer to the data sheet for applications, limits on use and possibilities.
- Certain media require or preclude the use of special materials.
- The valves are designed for standard operating conditions. If conditions exceed these requirements, e.g. aggressive or abrasive media, the operator should state the higher requirements when ordering.
- Valves made from grey cast iron are not authorised for use in systems subject to TRD 110.

The information complies to the Pressure Equipment Directive 97/23/EC.

It is the responsibility of the machine planner to ensure compliance.

The special markings on the valve must be taken into account.

Refer to the catalogue sheet to see which materials are used in standard versions.

Please contact the supplier or the manufacturer if you have any questions.

4.2 Operating principles

(refer to Fig. 2 page 4)

The double window sight glass allows visual inspection of flow in pipelines.

It has no moving parts.

The double window sight glass is installed in the pipeline upstream of the steam trap.

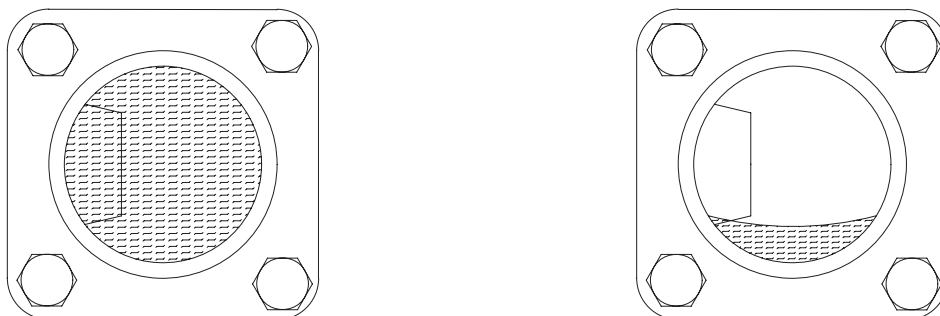

Fig. 1

Back pressure of condensate

If the pipeline is flooded due to back pressure, condensate (will back up) fill the glass with liquid.

Steam flow

On steam flow, the liquid level is lowered. Intensive mixture of water and steam can lead to an intensive bubbling.

4.3 Diagram

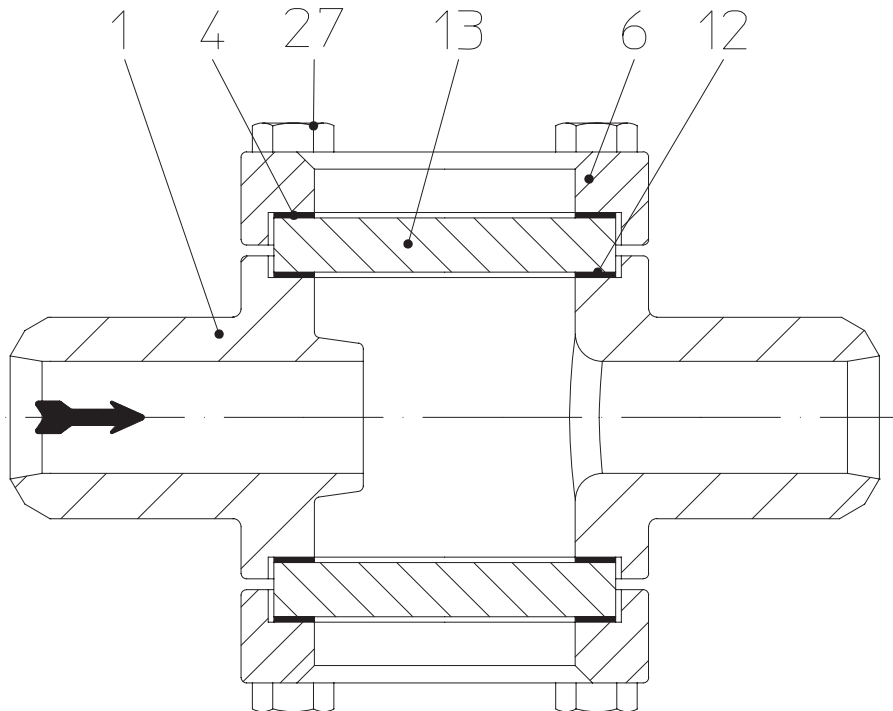

Fig. 2: Double window sight glass - series 660/661 PN16/40
DN10-125

Refer to the data sheet for information about materials with designations and figure numbers.

4.4 Technical data - remarks

for

- Principal dimensions,
- Pressure-temperature-ratings, operating limits,
- Valves with different types of connection , etc.
refer to datasheet.

4.5 Marking

Details of CE marking on valve:

CE CE-marking

0036 Notified body

Noris Manufacturer

Address of manufacturer:

Typ Type

refer to item 11.0 Warranty / Guarantee

Bj. Year of manufacture

According to the Pressure Equipment Directive appendix 2 diagram 7 valves acc. to article 1 paragraph 2.1.2 (pipes) only show the CE-marking from DN40 onwards.

5.0 Installation

5.1 General notes on installation

The following points should be taken into account besides the general principles governing installation work:



ATTENTION !

- Remove flange covers if present.
- The interior of valve and pipeline must be free from foreign particles.
- Installation in any position. Note installation position with reference to flow, see mark on valve.
- Steam line systems should be designed to prevent water accumulation.
- Lay pipelines so that damaging transverse, bending and torsional forces are avoided.
- Protect valves from dirt during construction work.
- Connection flanges must mate precisely.
- Valves must not be used to take external forces, e.g. they are not designed for use as climbing aids, or as connecting points for lifting gear.
- Suitable materials handling and lifting equipment should be used.
See data sheet for weights.
- Centre gaskets between the flanges.
- Precautions against freezing should be taken in any facilities susceptible to frost.

- Planners / construction companies or operators are responsible for positioning and installing products.

5.2 Installation instructions for welding

(refer to Fig. 2 page 4)

Please note that only qualified persons using appropriate equipment and working in accordance with technical rules are allowed to install fittings by welding.

The responsibility for this lies with the system owner.

Please refer to the catalogue sheet for information on type and instructions relating to welding socket weld ends/butt weld ends.

When welding products to the pipeline system these should be adequately cooled to prevent any adverse effect on the sight glass plate (Pos. 13), the interlayer (Pos. 4) and the flat gasket (Pos. 12). The heat-affected zone should be restricted to the immediate weld seam area!

Note pre- and post-welding heat treatment in accordance with Material Fact Sheet DIN EN 10222.

5.3 Installation position

(refer to Fig. 2 page 4)

The double window sight glass can be operated in a horizontal and vertical installation position without modification.

It should be installed upstream of the steam trap.

6.0 Putting the valve into operation



ATTENTION !

- *Before putting the valve into operation, check material, pressure, temperature and direction of flow.*
- *Regional safety instructions must be adhered to.*
- *Residues in piping and valves (dirt, weld beads, etc.) inevitably lead to leakage.*
- *Touching the valve when it is operating at high (> 50 °C) or low (< 0 °C) media temperatures can cause injury.*

Affix warning notice or protective insulation as appropriate!

Before putting a new plant into operation or restarting a plant after repairs or modification, always make sure that:

- *All works has been completed!*
- *The valve is in the correct position for its function.*
- *Safety devices have been attached.*

7.0 Care and maintenance

Maintenance and maintenance-intervals have to be defined by the operator according to the requirements.

	<p>ATTENTION !</p> <p>- refer to item 10.0 and 11.0 prior to dismantling and repair work!</p> <p>- refer to item 6.0 before restarting the plant !</p> <p><i>Prior to installation, threads and seal faces should be coated with temperature-stable lubricant (e.g. "OKS Anti-Seize Paste" white/metal-free for PN 16-40 or "Rivolta" lubricant and parting agent silver for PN 63 onwards).</i></p>
---	---

After start-up the sight glass unions (Pos. 28) should be carefully retightened. (see 7.1).
If sight glasses are replaced, the seals (Pos. 12) and interlayer (Pos. 4) should be replaced at the same time.

7.1 Tightening torques

(refer to Fig. 2 page 4)

Pos.	Double window sight glass PN16/40	Torque (Nm)	
		DN10-25	DN40-125
28	Hex. nut	30	60

8.0 Troubleshooting

In the event of malfunction or faulty operating performance check that the installation and adjustment work has been carried out and completed in accordance with these Operating Instructions.

	<p>ATTENTION !</p> <p>It is essential that the safety regulations are observed when identifying faults.</p>
---	--

If malfunctions cannot be eliminated with the help of the following table "9.0 troubleshooting table", the supplier or manufacturer should be consulted.

9.0 Troubleshooting table

	<p>ATTENTION !</p> <p>- refer to item 10.0 and 11.0 prior to dismantling and repair work!</p> <p>- refer to item 6.0 before restarting the plant !</p>
---	---

Fault	Possible cause	Corrective measures
No flow	Flange covers not removed	Remove flange covers
Little flow	Piping system clogged	Check piping system
External leakage	Hexagon nuts (Pos. 28) on cover not properly tightened	Tighten; see 7.1

10.0 Dismantling the valve or the body



ATTENTION !

The following points must be observed:

- *Pressureless pipe system.*
- *Medium must be cool.*
- *Plant must be drained.*

11.0 Warranty / Guarantee

The extent and period of warranty cover are specified in the "Standard Terms and Conditions of Albert Richter GmbH & Co. KG" valid at the time of delivery or, by way of departure, in the contract of sale itself.

We guarantee freedom of faults in compliance with state-of-the-art technology and the confirmed application.

No warranty claims can be made for any damage caused as the result of incorrect handling or disregard of operating and installation instructions, datasheets and relevant regulations.

This warranty also does not cover any damage which occurs during operation under conditions deviating from those laid down by specifications or other agreements.

Justified complaints will be eliminated by repair carried out by us or by a specialist appointed by us.

No claims will be accepted beyond the scope of this warranty. The right to replacement delivery is excluded.

The warranty shall not cover maintenance work, installation of external parts, design modifications or natural wear.

Any damage incurred during transport should not be reported to us but *rather* to the competent cargo-handling depot, the railway company or carrier company immediately or else claims for replacements from these companies will be invalidated.



Technology for the Future.

GERMAN QUALITY VALVES

ARI-Armaturen Albert Richter GmbH & Co. KG, D-33756 Schloß Holte-Stukenbrock

Telephone (+49 5207) 994-0 Telefax (+49 5207) 994-158 or 159

Internet: <http://www.ari-armaturen.com> E-mail: info.vertrieb@ari-armaturen.com

12.0 EC declaration of conformity

Konformitätserklärung gem. DGRL 97/23 EG

*Declaration of Conformity
acc. to PED 97/23 EG*

NORIS
— ARMATUREN —
BURKENSTEIN GMBH

Hersteller:
Manufacturer:

NORIS Armaturen Burkenstein GmbH
Neumeyerstrasse 13
D-90411 Nürnberg

Beschreibung des Druckgerätes:
Description of pressure equipment:

Durchfluß-Schaugläser PN 10 - 40 nach
NORIS-Bauformen 880, 881, 882, 885, 920, 972
*Sight-flow-indicators PN 10 - 40
acc. to NORIS-Bauform 880, 881, 882, 885, 920, 972*

Konformitätsbewertungsverfahren:
Conformity valuation procedure:

Modul A / A1

Benannte Stelle:
Number of notified body:

TÜV Süddeutschland **CE** 0036

Bestimmungsgemäße Verwendung
der Druckgeräte:
Agreed application of pressure equipment:

Einsatz der Schaugläser in Rohrleitungen zur optischen Beobachtung des Mediums innerhalb der zulässigen Druck- und Temperaturgrenzen unter Beachtung der chemischen und korrosiven Einflüsse auf das Schauglas. Der Einsatz in Fluidgruppe 1 und 2 ist erlaubt. Auf den bestimmungsgemäßen Gebrauch wird hingewiesen.
Sight-flow-indicators are suitable for optical control of fluids and gases, within the permissible limits of pressure and temperature. Chemical effects and corrosion are to be taken into account. Suitable fluid group: 1 and 2. Agreed application is reminded.

Harmonisierende Normen:
Harmonized European Standards:

AD 2000 Regelwerk

Andere Normen und Regelwerke:
Other Standards and rules:

TRB 801-Nr. 45
DIN 3236 / DIN 3237
DIN 8902 / DIN 7080

NORIS Armaturen Burkenstein GmbH bescheinigt hiermit, daß Konstruktion, Herstellung und Prüfung der Schaugläser den Anforderungen der Richtlinie 97/23/EG entsprechen.
NORIS Armaturen Burkenstein GmbH declares, that design, manufacturing and testing of the sight-glasses are corresponding to PED 97/23/EG.

Nürnberg, 15.05.2002

.....
Der Werksachverständige / Works inspector