

**Liquid drainer  
PN16 / PN40**

- with flanges (Fig. 665....1)
- with screwed sockets (Fig. 665....2)
- with socket weld ends (Fig. 665....3)
- with butt weld ends (Fig. 665....4)
- union with butt weld ends (Fig. 665....5)

Grey cast iron  
Forged steel  
Fig. 665

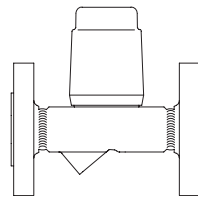

Page 2

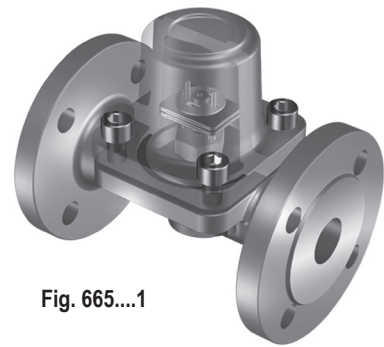
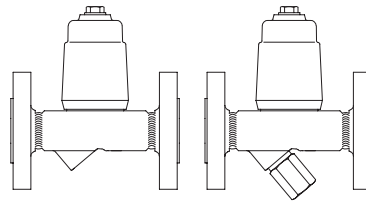

Fig. 665....1

**Condensate discharge  
temperature limiter  
PN40**

- with flanges (Fig. 645/647....1)
- with screwed sockets (Fig. 645/647....2)
- with socket weld ends (Fig. 645/647....3)
- with butt weld ends (Fig. 645/647....4)

Forged steel  
Fig. 645/647 (Y)



Page 4

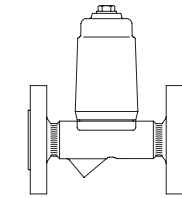

Fig. 647....1

**Return temperature limiter  
PN25 / PN40**

- with flanges (Fig. 650....1)
- with screwed sockets (Fig. 650....2)
- with socket weld ends (Fig. 650....3)
- with butt weld ends (Fig. 650....4)

Forged steel  
Fig. 650



Page 6

**Flow indicator  
(Double window sight glasses)  
PN16 / PN40**

- with flanges (Fig. 660....1)
- with screwed sockets (Fig. 660....2)
- with butt weld ends (Fig. 660....4)

Grey cast iron  
Cast steel  
Stainless steel  
Fig. 660

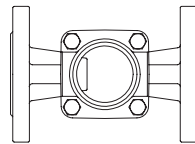

Page 10

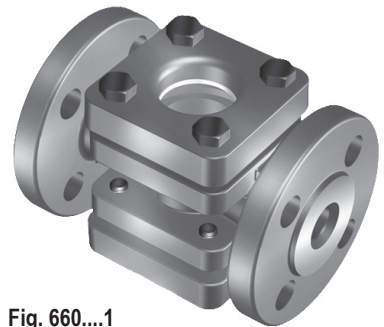
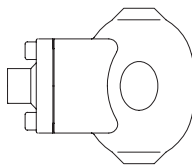

Fig. 660....1

**Automatic air vent for liquid systems**

- PN16 / PN25**
- with flanges (Fig. 656....1)
  - with screwed sockets (Fig. 656....2)
  - with socket weld ends (Fig. 656....3)
  - with butt weld ends (Fig. 656....4)

SG iron  
Cast steel  
Stainless steel  
Fig. 656



Page 12

**Vacuum breaker  
PN16 / PN40**

- with screwed sockets (Fig. 655....2)

Stainless steel  
Fig. 655

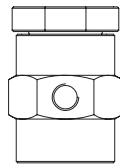

Page 14

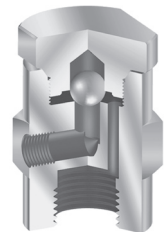

Fig. 655....2

**Steam injector  
PN25**

- with internal thread (Fig. 651....2)
- with butt weld ends (Fig. 651....4)

Stainless steel  
Fig. 651



Page 15

**Liquid drainer (Grey cast iron, Forged steel)**

- Automatic condensate-discharge during start-up and shut down
- On unpressurized system the liquid drainer will be opened by a compression spring inside of the controller
- On factory setting the liquid drainer will be closed at a differential pressure of  $\geq 1,5$  bar. Other factory settings between 0,5 bar and 2 bar possible.
- Bimetallic elements will achieve that the closing pressure is constant
- Installation in any position  
(if a frost resistant execution is required please inquire)

**Operating limits**

Fig. 12.665	PN16 - EN-JL1040	
Operating pressure PS (bar-g)	12,8	9,6
Operating temperature TS (°C)	200	300

allowable differential pressure $\Delta PMX$ (bar):	1,5
---	-----

Fig. 45.665	PN40 - 1.0460		
Operating pressure PS (bar-g)	32	22	14,5
Operating temperature TS (°C)	250	385	450

allowable differential pressure $\Delta PMX$ (bar):	1,5
---	-----

1.4541 on request.

**Types of connection**

Flanges ...1	PN16 / PN40 acc. to DIN 2501
Screwed sockets ....2	Rp- and NPT-Thread acc. to DIN EN 10226-1
Socket weld ends ....3	acc. to DIN EN 12670
Butt weld ends ....4	acc. to DIN EN 12627
Union with butt weld ends ...5	acc. to data sheet resp. customer request

Other types of connection on request.

For ANSI versions refer to data sheet CONA®-ANSI Komponenten

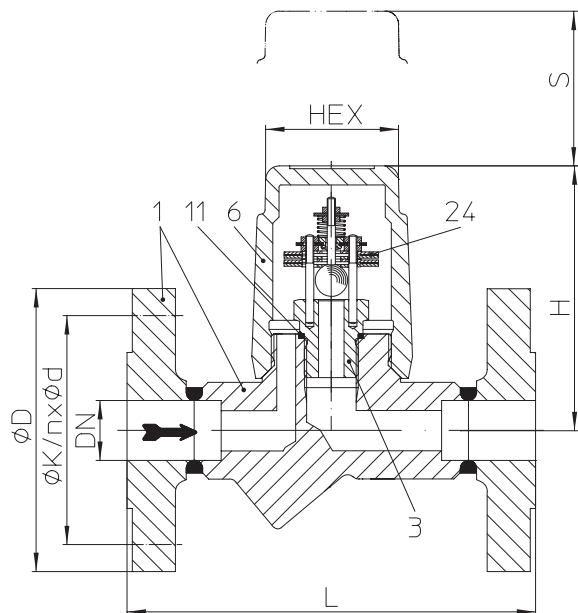

Fig. 665....1 with flanges

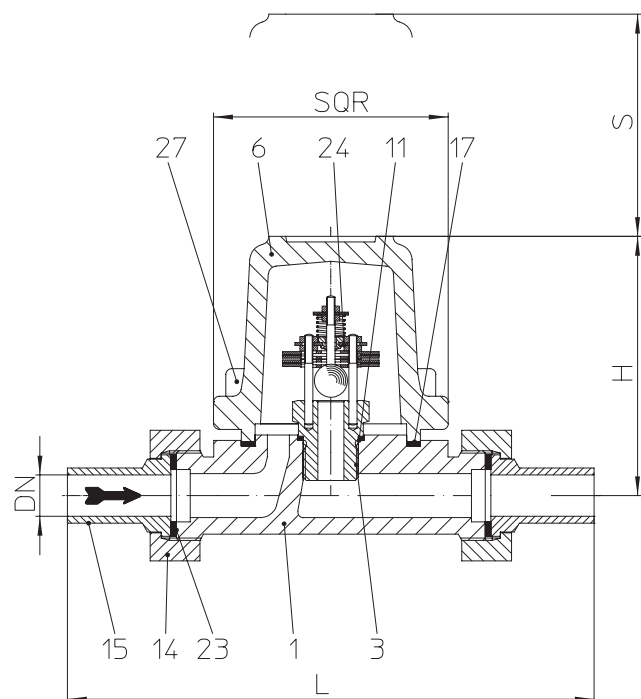

Fig. 665.... Union with butt weld ends (only PN16)

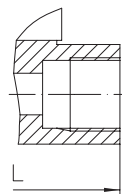

Fig. 665....2 with screwed sockets

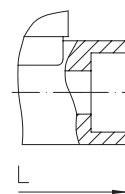

Fig. 665....3 with socket weld ends

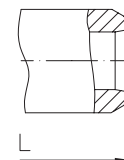

Fig. 665....4 with butt weld ends

Dimensions and Weights		Types of connection PN16			Types of connection PN40								
		Flanges	Union with butt weld ends		Flanges			Screwed sockets Socket weld ends			Butt weld ends		
Nominal diameter	(mm)	25	15	20	15	20	25	15	20	25	15	20	25
L *	(mm)	160	190	190	150	150	160	95	95	95	250	250	250
H	(mm)	100	100	100	98	98	98	98	98	103	98	98	98
S	(mm)	70	70	70	70	70	70	70	70	70	70	70	70
HEX	(mm)	50	50	50	50	50	50	50	50	50	50	50	50
SQR	(mm)	85	85	85	85	85	85	85	85	85	85	85	85
Weight approx.	(kg)	4,5	2,6	2,3	5,4	2,6	2,3	2,2	2,3	2,4	2,9	2,8	2,6

Standard-flange dimensions refer to page 16.

\* Face-to-face acc. to data sheet resp. customer request

**Parts**

Pos.	Description	Fig. 12.665	Fig. 45.665
1	Body	EN-GJL-250, EN-JL1040	P250GH, 1.0460
6	Cover / Screw cap	EN-GJL-250, EN-JL1040	P250GH, 1.0460
11	Sealing ring *	R-Cu99 or X6CrNiTi18-10, 1.4541	X6CrNiTi18-10, 1.4541
14	Sleeve nut	X14CrMoS17+QT, 1.4104+QT	--
15	Welding end	C 15, 1.0401	--
17	Gasket *	Pure graphite (CrNi laminated with graphite)	--
23	Sealing ring *	Pure graphite (CrNi laminated with graphite)	--
24	Controller, cpl.. *	TB 102 / 85 (corrosion resistant bimetal)	
27	Cylinder screw	A2-70	--

\* Spare part

Information / restriction of technical rules need to be observed!

Operating instructions can be ordered by phone +49 (0)5207 / 994-0 or fax +49 (0)5207 / 994-158 or -159.

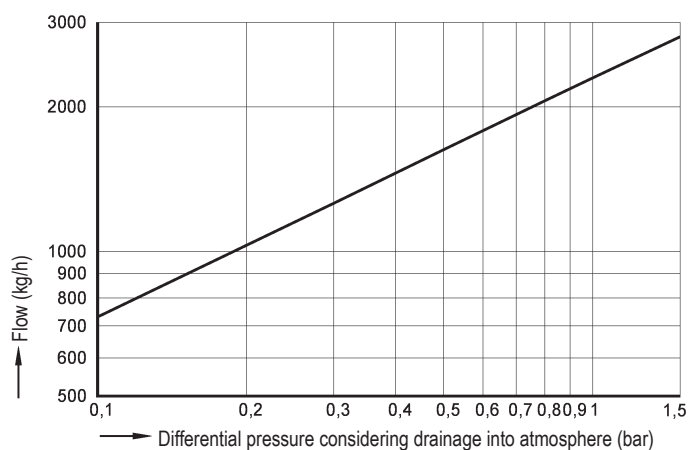
**Capacity chart**

The capacity chart shows the maximum flow quantities of cold condensate at about 20°C.

**Selection criteria:**

- Closing pressure
- Nominal diameter / pressure
- Type of connection
- Material
- Place of service

**Example for order data:**

For the condensate discharge from a steam pipe,  $\Delta P=3$  bar, max. flow 700 kg/h, flange connection, PN16, DN25

=> **Liquid drainer, Fig. 665, PN16, DN25, EN-JL1040, Face-to-face dimension 160 mm, with flanges**

Condensate discharge temperature limiter (Forged steel)

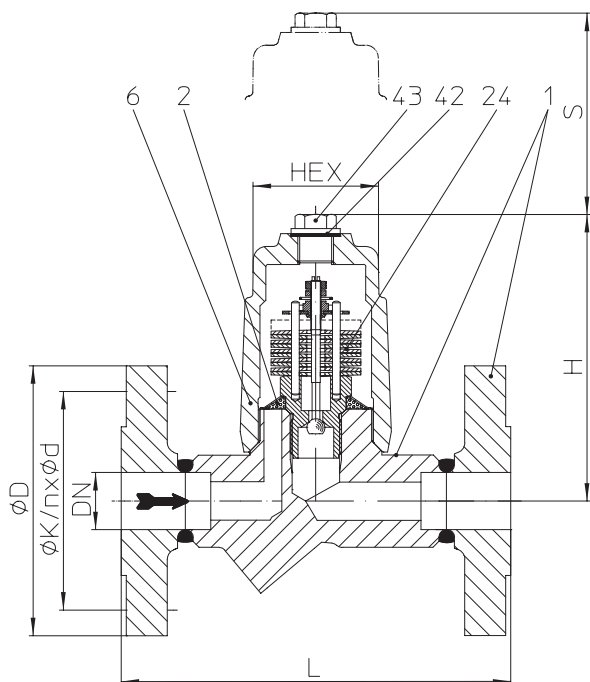

Fig. 645....1 with flanges

- Steam trap for the discharge of condensate without re-evaporation at adjustable condensate temperatures (temperature range from 60°C up to 140°C).
- With corrosion- and waterhammer resistant bimetallic controller
- Automatic air-venting during start-up and operation of the installation
- Installation in any position, except cap upside down
- Integrated non return protection
- With inside strainer - Fig. 645  
With outside strainer - Fig. 647 (Y)
- Subcooling of condensate is continuously adjustable (observe the operation instructions)
- The exchange of the controller is possible without disturbing the pipe connections
- For the utilization in warm water and hot water plants
- Options:
  - with blow down valve (Pos. 46)
  - with thermometer insert (Pos. 47 and 48) (only with inside strainer)

Operating limits

Fig. 45.645 / 45.647	PN40 - 1.0460		
Operating pressure PS (bar-g)	32	22	14,5
Operating temperature TS (°C)	250	385	450
allowable differential pressure ΔPMX (bar):	32		

Types of connection

Flanges ....1	PN40 acc. to DIN 2501
Screwed sockets ....2	Rp- and NPT-thread acc. to DIN EN 10226-1
Socket weld ends ....3	acc. to DIN EN 12760
Butt weld ends ....4	acc. to DIN EN 12627

Other types of connection on request.

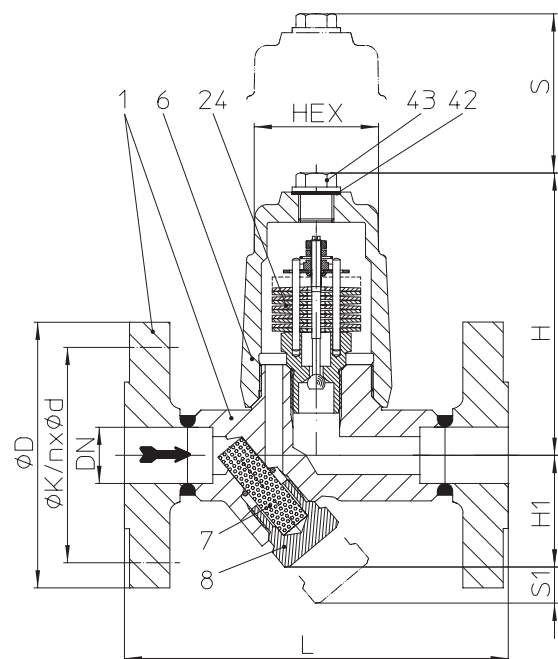

Fig. 647.... with flanges

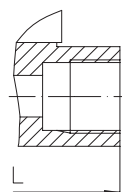

Fig. 645/647....2 with screwed sockets

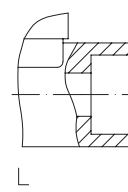

Fig. 645/647....3 with socket weld ends

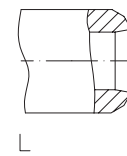

Fig. 645/647....4 with butt weld ends

Dimensions and Weights		Types of connection								
		Flanges			Screwed sockets Socket weld ends			Butt weld ends		
Nominal diameter	(mm)	15	20	25	15	20	25	15	20	25
L *	(mm)	150	150	160	95	95	95	250	250	250
H	(mm)	112	112	112	112	112	121	112	112	112
H1	(mm)	65	65	65	65	65	58	65	65	65
S	(mm)	80	80	80	80	80	80	80	80	80
S1	(mm)	30	30	30	30	30	30	30	30	30
HEX	(mm)	50	50	50	50	50	50	50	50	50
Weight approx.	(kg)	3,6	4,3	5,6	2	2,4	2,4	2,2	2	2

Standard-flange dimensions refer to page 16.

\* Face-to-face acc. to data sheet resp. customer request

**Parts**

Pos.	Description	Fig. 45.645 / 45.647
1	Body	P250 GH, 1.0460
2	Screen *	X5CrNi18-10, 1.4301
6	Screw cap	P250 GH, 1.0460
7	Strainer screen *	X5CrNi18-10, 1.4301
8	Strainer plug *	X6CrNiTi18-10, 1.4541
24	Controller *	TB 102 / 85 (corrosion resistant bimetal)
42	Sealing ring *	A4
43	Plug *	C35E, 1.1181
46	Blow down valve, cpl.	X6CrNiTi18-10, 1.4541
47	Thermometer adapter *	X14CrMoS17+QT, 1.4104+QT
48	Thermometer display *	X8CrNiS18-9, 1.4305

\* Spare part

Information / restriction of technical rules need to be observed!

Operating instructions can be ordered by phone +49 (0)5207 / 994-0 or fax +49 (0)5207 / 994-158 or -159.

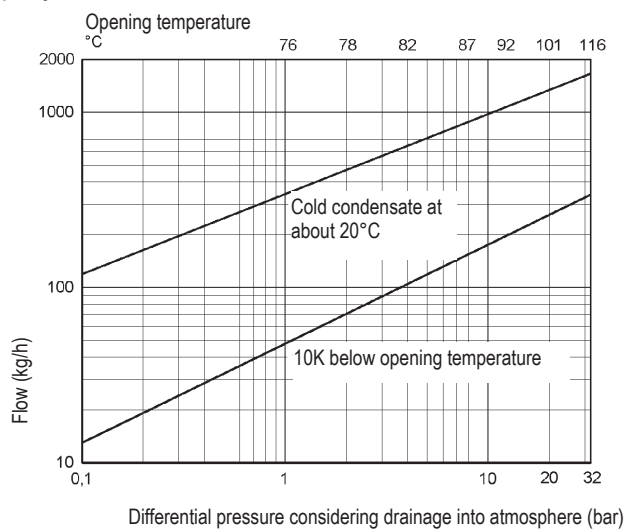
**Capacity chart**

The capacity chart shows the maximum flow quantities of cold condensate at about 20°C and condensate at 10K below the opening temperature based on the factory setting.

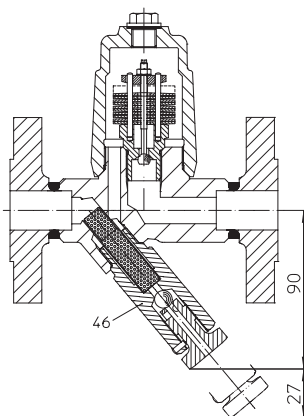
**Options:**

Outside strainer with blow down valve (Fig. 648)

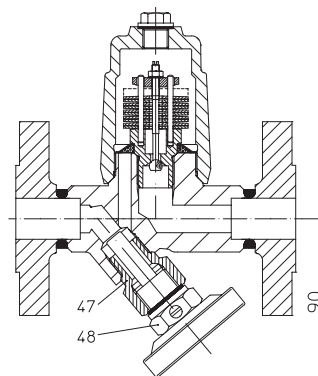
**Options:**

Thermometer insert with adapter  
 (Indicating range: 0°C up to 160°C) standard,  
 (up to 250°C on request)

**Selection criteria:**

- Inlet press.
- Back pressure
- quantity of condensate
- Nominal diameter / pressure
- Type of connection
- Material
- Options

**Example for order data:**

For the condensate discharge from a steam pipe, Operating pressure P1=4 bar(g), max. flow 50 kg/h, opening temperature 80 °C, flange connection, PN40, DN25

=> **Condensate discharge temperature limiter, Fig. 647, PN40, DN25, 1.0460, Face-to-face dimension 160 mm, flange connection, with thermometer.**

**Return temperature limiter (Forged steel)**

Fig. 650...1 with flanges

 Fig. 650...2  
 with screwed sockets

 Fig. 650...3  
 with socket weld ends

 Fig. 650...4  
 with butt weld ends

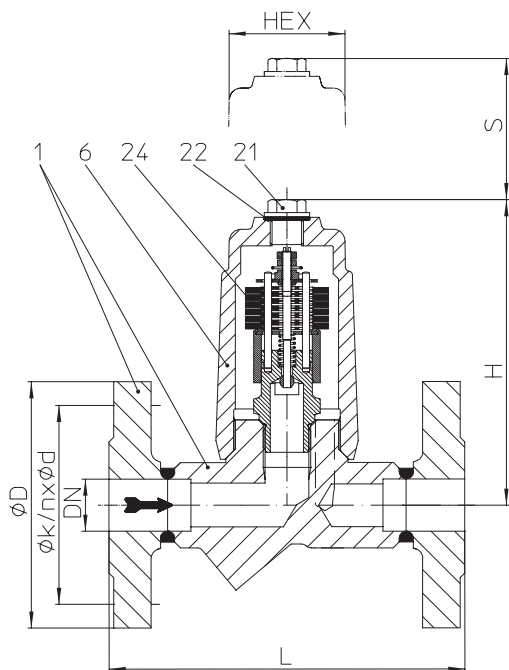
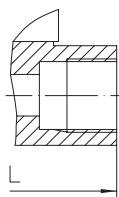
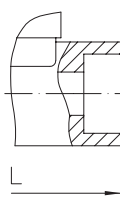
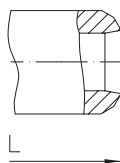
Liquid return temperature limiter is applied for the return of hot water or other suitable liquids in heating systems. Temperature guided but operating from the pressure, it is providing a consumption oriented supply of hot water to heating systems. Energy saving by using reduced flow return temperatures.

- With corrosion- and waterhammer resistant bimetallic controller
- The controller has a stroke-limitation at 130 °C thus even in case of an incorrect setting the function is performed
- Scope range of closing temperature from: 60° to 130 °C
- The exchange of the controller is possible without disturbing the pipe connections
- Optimized design for quick installation
- Maintenance simplified due to screwed cap without sealing
- Installation: horizontal installation position is preferred, inclined installation position of the screwed cap is possible
- Options:
  - with thermometer insert (pos. 47 and 48)
  - with external adjustment device (pos. 44) and extended setting range, with factory setting at 180°C

**Operating limits**

Fig. 44. / 45.650	PN25 / 40 - 1.0460
Operating pressure PS (bar-g)	22
Operating temperature TS (°C)	180
allowable differential pressure ΔPMX (bar):	6

**Types of connection**

Flanges ....1	PN25 / PN40 acc. to DIN 2501
Screwed sockets ....2	Rp- and NPT-thread acc. to DIN EN 10226-1
Socket weld ends ....3	acc. to DIN EN 12760
Butt weld ends ....4	acc. to DIN EN 12627

Other types of connection on request.

Dimensions and Weights		Types of connection								
		Flanges			Screwed sockets Socket weld ends			Butt weld ends		
Nominal diameter	(mm)	15	20	25	15	20	25	15	20	25
L*	(mm)	150	150	160	95	95	95	250	250	250
H	(mm)	130	130	130	130	130	135	130	130	130
S	(mm)	90	90	90	90	90	90	90	90	90
S1	(mm)	90	90	90	90	90	90	90	90	90
HEX	(mm)	50	50	50	50	50	50	50	50	50
Weight approx.	(kg)	3,4	4,0	4,4	2,1	2,0	2,5	2,6	2,7	2,8

Standard-flange dimensions refer to page 16.

Larger nominal diameters on page 8.

\* Face-to-face acc. to data sheet resp. customer request

**Parts**

Pos.	Description	Fig. 44.650 / 45.650
1	Body	P250 GH, 1.0460
6	Screw cap	P250 GH, 1.0460
21	Plug	C35E, 1.1181
22	Gasket *	A4
24	Controller *	TB 102 / 85 (corrosion resistant bimetal)
42	Gasket *	Cu
44	Cylinder screw HSE (Manual adjustment device)	X8CrNiS18-9, 1.4305
47	Thermometer adapter *	X6CrNiTi18-10, 1.4541
48	Thermometer display *	X6CrMoTi17-12-2, 1.4571
49	O-Ring *	FPM 80

\* Spare part

Information / restriction of technical rules need to be observed!

Operating instructions can be ordered by phone +49 (0)5207 / 994-0 or fax +49 (0)5207 / 994-158 or -159.

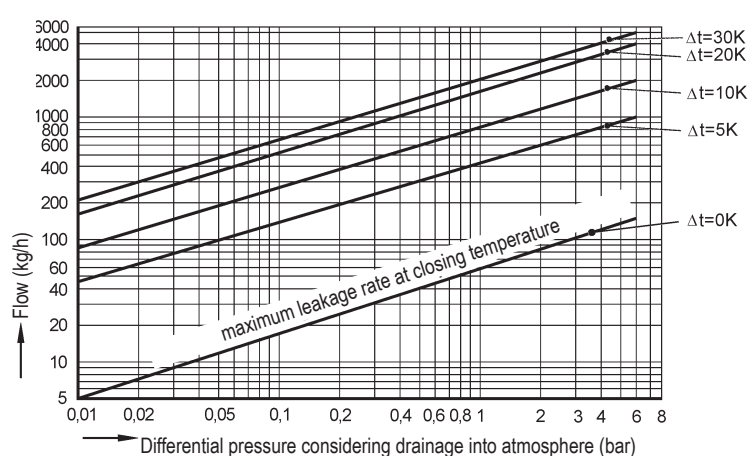
**Capacity chart**

The capacity chart shows the maximum capacity at factory setting (90°C).

The water-temperature determines the degree of opening of the controller. The lower temperature of the water the higher the flow quantity.

**Change of the factory setting**

After opening the cap in pressureless mode, an adjustment of the closing temperature can be done. A half turn of the screw clockwise results in an increase of temperature by about 10K.

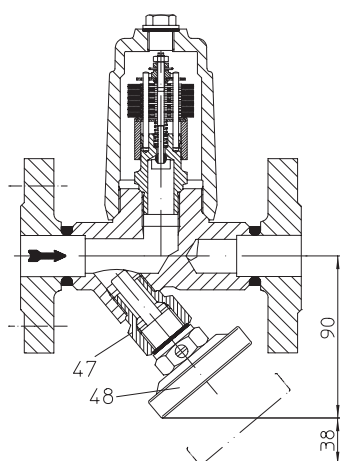
**Option:**

Option: Thermometer insert with adapter (Indicating range: 0°C up to 160°C) standard, (up to 250°C on request)

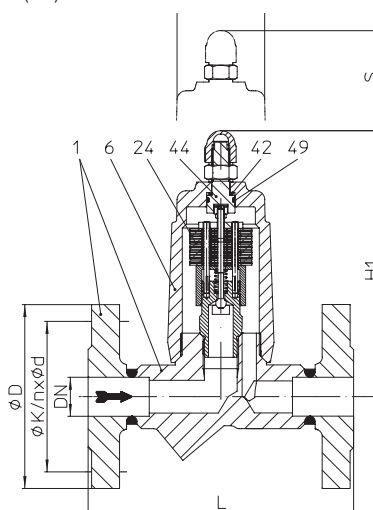
**Option:**

External adjustment device

**Selection criteria:**

- Closing pressure
- Operating pressure
- Back pressure/Differential pressure
- Flow quantity
- Upstream temperature
- Required closing temperature
- Nominal diameter / pressure
- Type of connection
- Material

**Example for order data:**

Return temperature limitation for a pipe tracing system., Inlet press. 4 bar(Ü), closing temperature 90°C, flange connection, PN40, DN15, 1.0460, Face-to-face dimension 150 mm.

=&gt; Return temperature limiter, Fig. 650, PN40, DN15, 1.0460, Face-to-face dimension 150 mm, T = 90°C, flange connection

**Return temperature limiter (Forged steel)**

Fig. 650....1 with flanges

Liquid return temperature limiter is applied for the return of hot water or other suitable liquids in heating systems. Temperature guided but operating from the pressure, it is providing a consumption oriented supply of hot water to heating systems. Energy saving by using reduced flow return temperatures.

- With corrosion- and waterhammer resistant bimetallic controller
- Scope range of closing temperature from up to 180 °C
- with external adjustment device (pos. 44) and extended setting range
- with factory setting at 90 °C
- The exchange of the controller is possible without disturbing the pipe connections
- Optimized design for quick installation
- Options: - with thermometer insert (pos. 47 and 48)

**Operating limits**

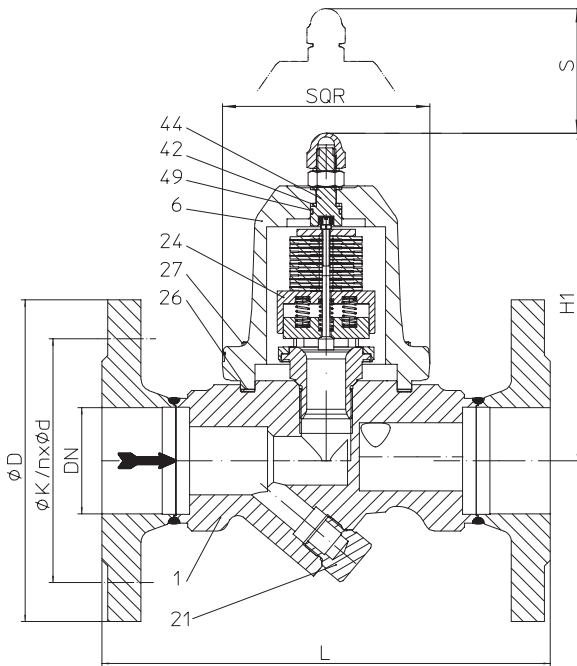
Fig. 44. / 45.650	PN25 / 40 - 1.0460
Operating pressure PS (bar-g)	22
Operating temperature TS (°C)	180
allowable differential pressure ΔPMX (bar):	6

**Types of connection**

Flanges ....1	PN25 / PN40 acc. to DIN 2501
Screwed sockets ....2	Rp- and NPT-thread acc. to DIN EN 10226-1
Socket weld ends ....3	acc. to DIN EN 12760
Butt weld ends ....4	acc. to DIN EN 12627

Other types of connection on request.

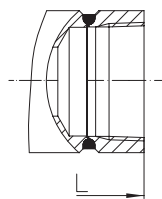
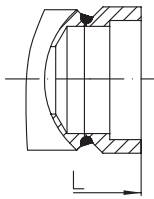
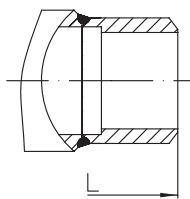
 Fig. 650....2  
with screwed sockets

 Fig. 650....3  
with socket weld ends

 Fig. 650....4  
with butt weld ends

Dimensions and Weights		Types of connection					
		Flanges		Screwed sockets <sup>1)</sup> Socket weld ends		Butt weld ends	
Nominal diameter	(mm) (inch)	40 1 1/2	50 2	40 1 1/2	50 2	40 1 1/2	50 2
L*	(mm)	230	230	130 / 160 <sup>1)</sup>	210	250	250
H1	(mm)	168	168	168	168	168	168
S	(mm)	100	100	100	100	100	100
SQR	(mm)	110	110	110	110	110	110
Weight approx.	(kg)	11,3	12,1	8	8	8,9	9,8

Standard-flange dimensions refer to page 16.

Smaller nominal diameters on page 6.

\* Face-to-face acc. to data sheet resp. customer request



**Parts**

Pos.	Description	Fig. 44.650 / 45.650
1	Body	P250 GH, 1.0460
6	Cover	P250 GH, 1.0460
21	Plug	X6CrNiTi18-10, 1.4541
22	Sealing ring	A4
26	Gasket *	Graphit
27	Zylinder screw	A2-70
24	Controller *	TB 102 / 85 (corrosion resistant bimetal)
42	Sealing ring *	Cu
44	Cylinder screw HSE (Manual adjustment device)	X8CrNiS18-9, 1.4305
47	Thermometer adapter *	X6CrNiTi18-10, 1.4541
48	Thermometer display *	X6CrMoTi17-12-2, 1.4571
49	O-Ring *	FPM 80

\* Spare part

Information / restriction of technical rules need to be observed!

Operating instructions can be ordered by phone +49 (0)5207 / 994-0 or fax +49 (0)5207 / 994-158 or -159.

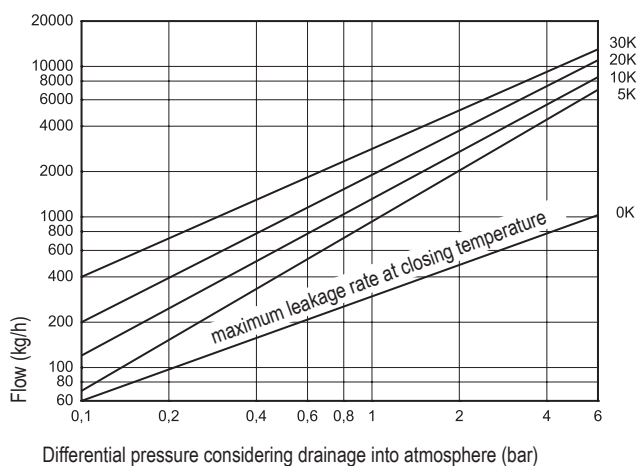
**Durchflussdiagramm**

The capacity chart shows the maximum capacity at factory setting (90°C).

The water-temperature determines the degree of opening of the controller. The lower temperature of the water the higher the flow quantity.

**Change of the factory setting**

A half turn of the screw clockwise results in an increase of temperature by about 8K.

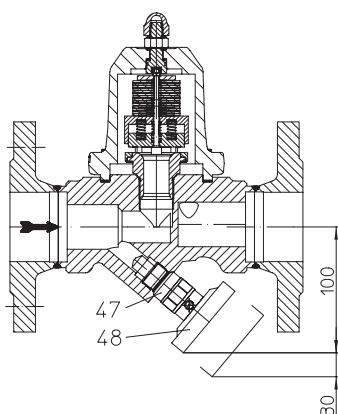
**Option:**

 Option: Thermometer insert with adapter  
 (Indicating range: 0°C up to 160°C) standard, (up to 250°C on request)

**Selection criteria:**

- Closing pressure
- Operating pressure
- Back pressure/Differential pressure
- Flow quantity
- Upstream temperature
- Required closing temperature
- Nominal diameter / pressure
- Type of connection
- Material

**Example for order data:**

Return temperature limitation for a pipe tracing system., Inlet press. 4 bar(Ü), closing temperature 90°C, flange connection, PN40, DN40, 1.0460, Face-to-face dimension 230mm.

=&gt; Return temperature limiter, Fig. 650, PN40, DN40, 1.0460, Face-to-face dimension 230mm, T=90°C, flange connection

**Flow indicator (Grey cast iron, Cast steel, Stainless steel)**

Fig. 660....1 with flanges

 Fig. 660....2  
 with screwed sockets

 Fig. 660....4  
 with butt weld ends

- Double window sight glasses in straight through
- Sight glasses provide visual indication of the flow through pipe works and monitoring of the system.
- In connection with steam traps they will allow the monitoring of the function of steam traps
- Installation in any position. In connection with the steam trap the sight glass has to be installed in front of it.
- **Sight glasses with reinforced windows in acc. to DIN 3237**

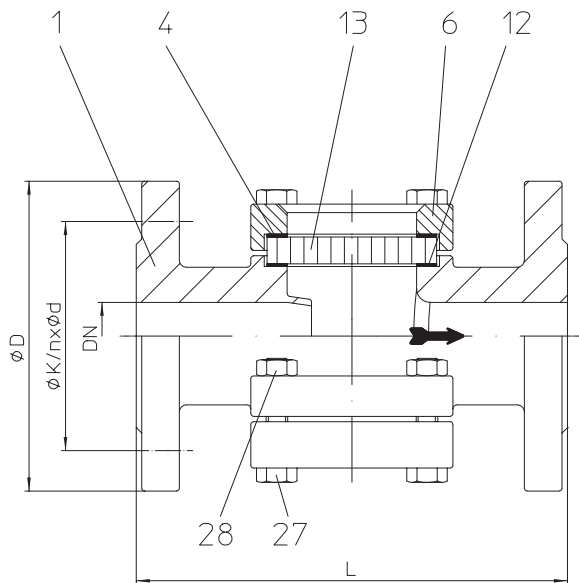
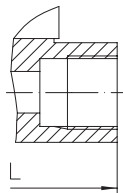
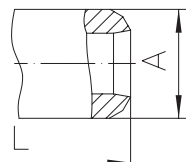
**Operating limits**

Fig. 12.660 / 32.660 / 52.660	PN16 EN-JL1040, 1.0619+N, 1.4408	
Operating pressure PS (bar-g)	16	10,2
Operating temperature TS (°C)	120	280
	(borosilicate glass)	
max. pH-value:	9-10	

Fig. 35.660 / 55.660	PN40 - 1.0619+N, 1.4408	
Operating pressure PS (bar-g)	40	28
Operating temperature TS (°C)	120	280
	(borosilicate glass)	
max. pH-value:	9-10	

**Types of connection**

Flanges ....1	PN16 / PN40 acc. to DIN 2501
Screwed sockets ....2	G-thread acc. to DIN ISO 228 / NPT-thread acc. to DIN EN 10226-1
Butt weld ends ....4	acc. to DIN EN 12627

Other types of connection on request.

Dimensions and Weights		DN																
		NPS	1/4	3/8	1/2	3/4	1	1 1/4	1 1/2	2								
PN16	Flanges	L	(mm)	--	--	130	150	160	180	200	230	290	310	350	400	480	600	
		D	(mm)	--	--	95	105	115	140	150	165	185	200	220	250	285	340	
		Weight approx.	(kg)	--	--	3,6	4,2	6,5	8,1	10,5	14,5	23	32	41	47	on request		
	Screwed sockets	L (EN-JL1040)	(mm)	100	100	100	120	120	160	160	180	--	--	--	--	--	--	--
		L	(mm)	100	100	100	120	120	160	160	230	--	--	--	--	--	--	--
		SW	(mm)	36	36	36	46	46	75	75	80	--	--	--	--	--	--	--
	Weight approx.	(kg)	2,2	2,2	2,2	3,4	3,4	7	7	10	--	--	--	--	--	--	--	
PN40	Flanges	L	(mm)	--	--	130	150	160	180	200	230	290	310	350	400	480	600	
		D	(mm)	--	--	95	105	115	140	150	165	185	200	235	270	300	375	
		Weight approx.	(kg)	--	--	3,6	4,2	6,5	8,1	11,5	14,9	23	33	43	50	on request		
	Screwed sockets	L	(mm)	100	100	100	120	120	160	160	230	--	--	--	--	--	--	--
		SW	(mm)	36	36	36	46	46	75	75	80	--	--	--	--	--	--	--
		Weight approx.	(kg)	2,2	2,2	2,2	3,4	3,4	7	7	10	--	--	--	--	--	--	--
Butt weld ends (not in EN-JL1040)	L	(mm)	--	100	100	100	120	120	160	230	290	310	350	400	480	600		
	A	(mm)	--	20	22	28	34	42	49	61	77	90	115	141	170	222		
	Weight approx.	(kg)	--	2,2	2,2	2,2	4	4	7	10	18	25	32	35	on request			

Standard-flange dimensions refer to page 16.

Face-to-face acc. to data sheet resp. customer request

**Parts**

Pos.	Description	Fig. 12.660	Fig. 32.660 Fig. 35.660	Fig. 52.660 Fig. 55.660
1	Body	EN-JL1040, EN-GJL-250	GP240GH+N, 1.0619+N	GX5CrNiMo19-11-2, 1.4408
4	Gasket *	Aramide fibre C4400		
6	Cover flange	EN-JL1040, EN-GJL-250	GP240GH+N, 1.0619+N	GX5CrNiMo19-11-2, 1.4408
12	Gasket *	Graphite		
13	Window *	borosilicate glass DIN 7080 max. 280°C		
27	Hexagon screw	5.6 zinc coated	5.6 zinc coated	A4-70
28	Hexagon nut	5		A4-70

\* Spare part (Pos. 4, 12, 13 will be supplied as unit)

Information / restriction of technical rules need to be observed!

Operating instructions can be ordered by phone +49 (0)5207 / 994-0 or fax +49 (0)5207 / 994-158 or -159.

**Flow conditions through a sight glass installed in front of a steam trap**

Figure 1: Back pressure of condensate

On a back pressure of condensate the interior space will be filled with liquid..

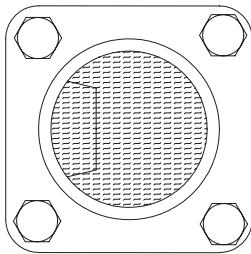
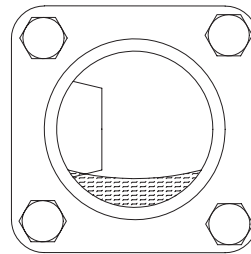

Figure 2: Steam flow

On steam flow the liquid level is lowered below the edge of the inlet pipe. Intensive mixture of water and steam can lead to an intensive bubbling.

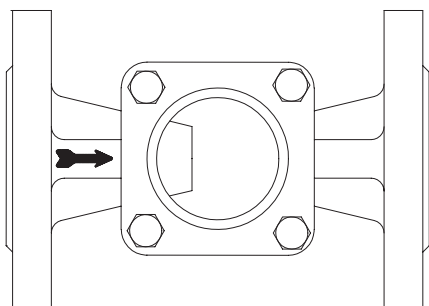

Figure 3: Tetragonal top flange (< DN 65)

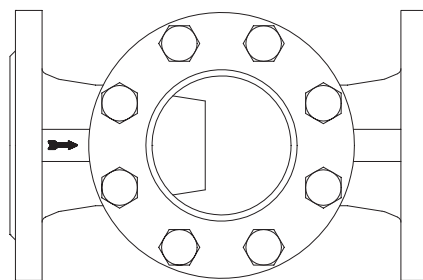

Figure 4: Circular top flange (DN65-250)

**Selection criteria:**

- Operating pressure
- Operating temperature
- Nominal diameter / pressure
- Type of connection
- Body-Material

**Example for order data:**

For monitoring the function of steam traps in pipe work systems, PS= 22 bar, TS = 250 °C, screwed socket G 1/2, body of stainless steel, window borosilicate glass DIN 7080-16.

=> **Flow indicator, Fig. 660, G 1/2, PN16, Stainless steel, Face-to-face dimension 100 mm, Screwed sockets.**

Automatic air vent for liquid systems (SG iron, Cast steel, Stainless steel)

- Automatic air vents for liquid systems
- Hood with flanged cover
- The exchange of the controller is possible without disturbing the pipe connections
- Installation: above the point being vented, inlet always at the bottom
- Options:
  - Drip pipe (Pos. 54)
  - with Union M14x1,5 for pipe-ø 8 mm (Pos. 53)

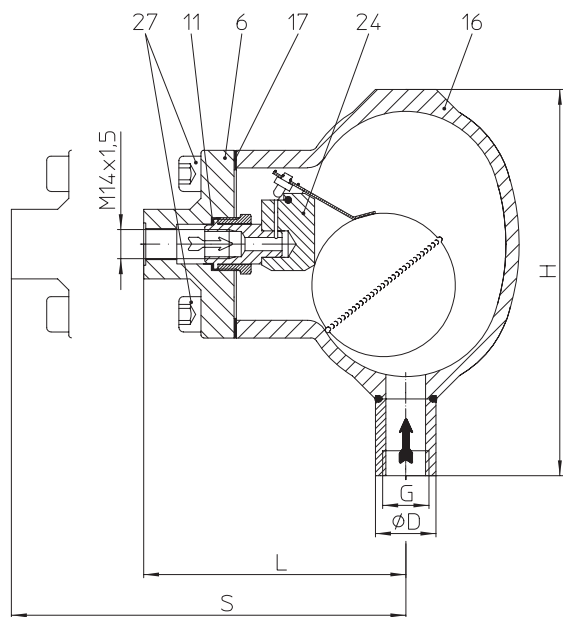

Fig. 656...2 (PN16) with screwed sockets

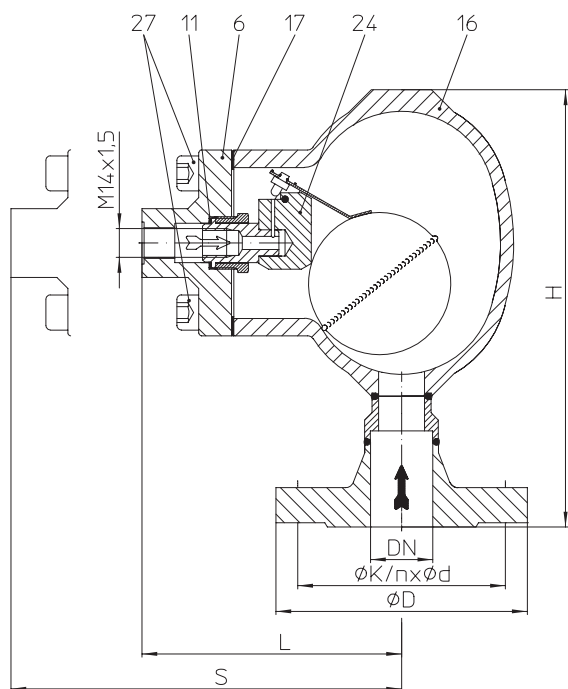

Fig. 656... with Flange

Operating limits

Fig. 22.656	PN16 - EN-JS1049
Operating pressure PS (bar-g)	14
Operating temperature TS (°C)	300

allowable differential pressure ΔPMX (bar):	14
for controller:	R14

Fig. 34.656	PN25 - 1.0619+N
Operating pressure PS (bar-g)	21
Operating temperature TS (°C)	225

allowable differential pressure ΔPMX (bar):	21
for controller:	R21

Fig. 54.656	PN25 - 1.4308
Operating pressure PS (bar-g)	21
Operating temperature TS (°C)	300

allowable differential pressure ΔPMX (bar):	21
for controller:	R21

Types of connection

Inlet:	
Flange ....1	DIN PN25
Screwed sockets .... 2	Rp- and NPT-thread acc. to DIN EN 10226-1 (bei PN16 - EN-JS1049 only Rp 1/2")
Socket weld ends ....3	acc. to DIN EN 12760
Butt weld ends .... 4	acc. to DIN EN 12627
Outlet:	
M14 x 1,5 DIN 13	

Other types of connection on request.

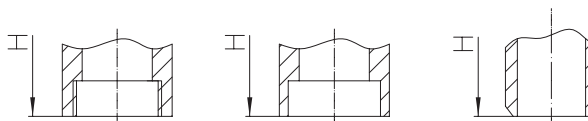

Fig. 656...2 (PN25) with screwed sockets

Fig. 656...3 with socket weld ends

Fig. 656...4 with butt weld ends



Dimensions and Weights		Types of connection								
		Flanges			Screwed sockets <sup>1)</sup> Socket weld ends (not EN-JS1049)			Butt weld ends (not EN-JS1049)		
Nominal diameter	(mm)	15	20	25	15	20	25	15	20	25
H	(mm)	196	197	200	140 <sup>1)</sup> / 175	175	186	175	175	186
L	(mm)	119	119	119	119	119	119	119	119	119
S	(mm)	238	238	238	238	238	238	238	238	238
Weight approx.	(kg)	4,8	5,3	5,6	4,3	4,4	4,4	4,3	4,4	4,4

<sup>1)</sup> Screwed sockets: L = 140

Standard-flange dimensions refer to page 16

Parts

Pos.	Description	Fig. 22.656	Fig. 34.656	Fig. 54.656
6	Cover	P250GH, 1.0460		X6CrNiTi18-10, 1.4541
11	Sealing ring *	A4		X6CrNiTi18-10, 1.4541
16	Hood	EN-JS1049, EN-GJS-400-18U-LT	GP240GH+N, 1.0619+N	GX5CrNi19-10, 1.4308
17	Gasket *	Pure graphite CrNi laminated with graphite		
24	Controller *	X5CrNi18-10, 1.4301		
27	Cylinder screw	X6CrNiTi18-10, 1.4541		
53	Union joint for drip pipe *	X8CrNiS18-9, 1.4305		
54	Drip pipe *	X6CrNiMoTi17-12-2, 1.4571		

\* Spare part

Information / restriction of technical rules need to be observed!

Operating instructions can be ordered by phone +49 (0)5207 / 994-0 or fax +49 (0)5207 / 994-158 or -159.

Capacity chart

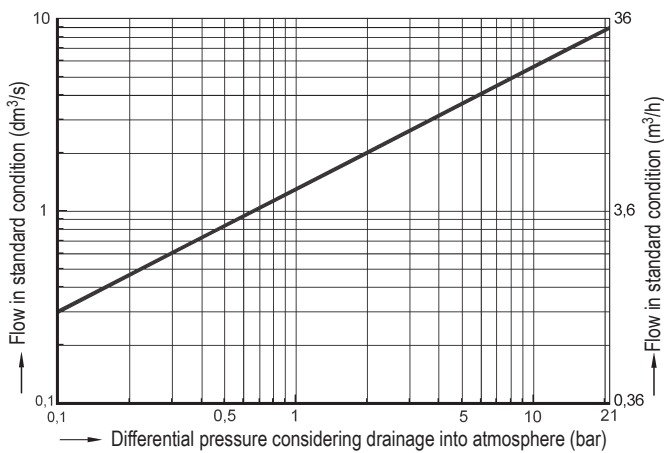

The diagram shows the maximum discharge of air at standard condition.

Options

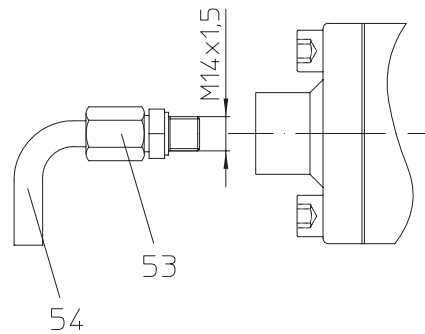

Drip pipe (angle) with union joint

For higher performance with mounted vacuum breaker (BR655)

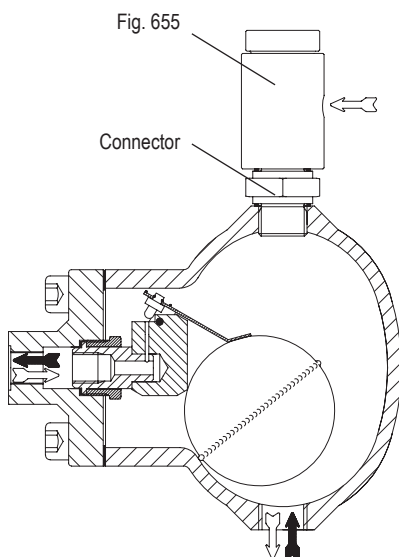

with connector and vacuumbreaker (BR655)

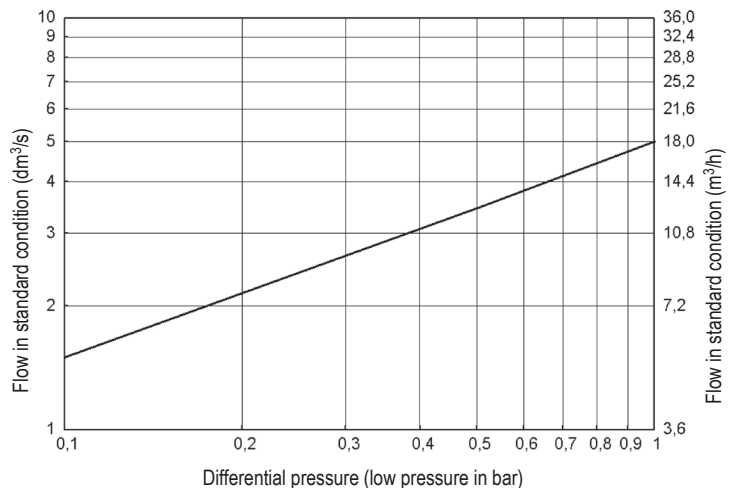

The diagram shows the maximum discharge of air at standard condition with mounted vacuumbreaker.

Vacuum breaker (Stainless steel)

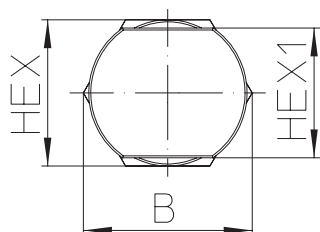
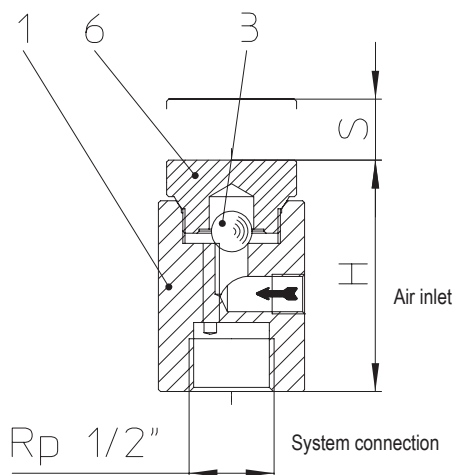

Fig. 655....2 with screwed sockets

- Ventilation valve for pipelines, condensing vapour (steam) or liquid systems, where the system pressure should not fall below the atmospheric pressure.
- Vertical position, cap on top.
- System connection downwards.

Operating limits

Fig. 55.655	PN40 - 1.4301	
Operating pressure PS (bar-g)	13	21
Operating temperature TS (°C)	400	220

Types of connection

System connection ....2	Rp 1/2 (acc. to DIN EN10226-1)
Air inlet	Rp 1/8 (acc. to DIN EN10226-1)

A dropping line can be connected.  
The line has to be led to an outlet.

Technical data

Set pressure:	7 mbar
Kvs-value:	0,55 m <sup>3</sup> /h

Capacity chart

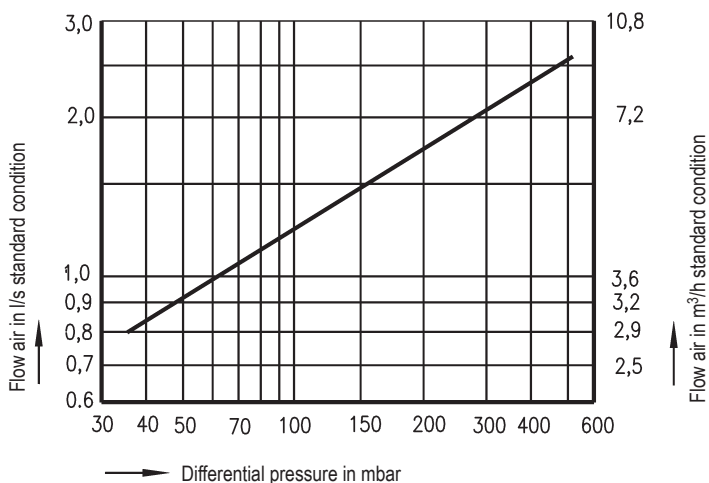

The diagram shows the maximum discharge of air at standard condition.

Dimensions and Weights		Types of connection	
		System connection	
Nominal diameter	(in)	Rp 1/2"	
H	(mm)	57	
B	(mm)	42	
S	(mm)	10	
HEX	(mm)	36	
HEX 1	(mm)	32	
Weight approx.	(kg)	0,38	

Parts

Pos.	Description	Fig. 55.655
1	Body	X5CrNi18-10, 1.4301
3	Ball	X20Cr13+Qt, 1.4021+QT
6	Cap	X17CrNi16-2, 1.4057

Information / restriction of technical rules need to be observed!

Operating instructions can be ordered by phone +49 (0)5207 / 994-0 or fax +49 (0)5207 / 994-158 or -159.

Steam injector (Stainless steel)

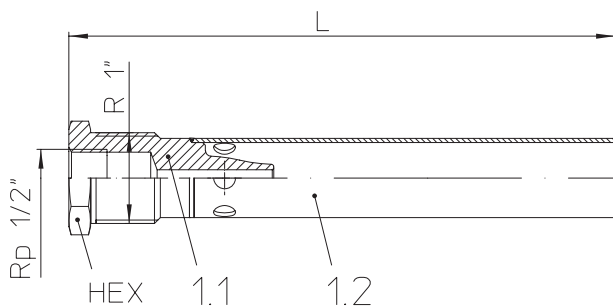

Fig.651....2 with internal thread (Rp 1/2) and external thread (R 1)

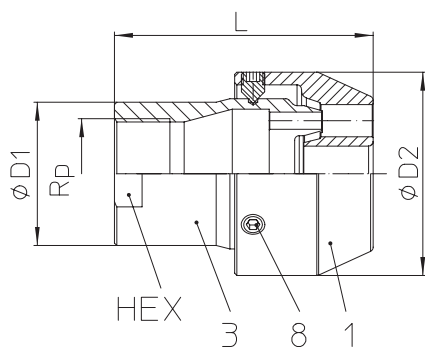

Fig.651....2 with internal thread (Rp 1 - Rp 1 1/2)

- Steam injector without moving parts
- Direct condensation of steam for heating water
- The released heat of condensation of the vapor is transferred directly to the water
- Installation position horizontally

Operating limits

<b>Fig. 54.651</b>	<b>PN25 - 1.4301 / 1.4305</b>
Operating pressure PS (bar-g)	17
Operating temperature TS (°C)	207

Types of connection

Internal thread ....2	Rp 1/2 and external thread R1 (acc. to DIN EN10226-1)
	Rp 1 up to 1 1/2 (acc. to DIN EN10226-1)
Butt weld ends ....4	acc. to DIN EN 12627

Capacity chart

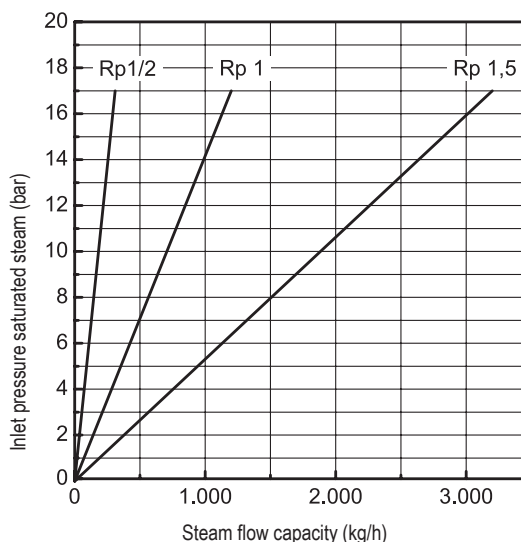

Dimensions and Weights		Types of connection				
		Internal thread			Butt weld ends	
Nominal diameter	(mm) (in)	DN15 Rp 1/2	DN25 Rp 1	DN40 Rp 1 1/2	DN25 1"	DN40 1 1/2"
L	(mm)	200	87	112	87	112
External thread R	(in)	1"	--	--	--	--
ØD1	(mm)	29	48	62	35	50
ØD2	(mm)	--	74	88	74	62
HEX	(mm)	36	41	55	--	--
Weight approx.	(kg)	0,4	1	2	1	2

Parts

Pos.	Description	Fig. 54.651....2 (1/2")	Fig. 54.651....2 (1" - 1 1/2")	Fig. 54.651....4 (1" - 1 1/2")
1	Head, (cpl.)	(X5CrNi18-10, 1.4301)	X8CrNiS18-9, 1.4305	
1.1	Head	X5CrNi18-10, 1.4301	--	
1.2	Pipe	X5CrNi18-10, 1.4301	--	
3	Nozzle	--	X8CrNiS18-9, 1.4305	X5CrNi18-10, 1.4301
8	Grub screw	--	A2	

Information / restriction of technical rules need to be observed!  
Operating instructions can be ordered by phone +49 (0)5207 / 994-0 or fax +49 (0)5207 / 994-158 or -159.

**Informations about pipe welding**

**Welding groove acc. to DIN 2559**

The material used for ARI valves with butt weld ends are:	1.0619+N	GP240GH+N acc. to DIN EN 10213-2
	1.0460	P250GH acc. to DIN EN 10222-2
	1.0401	C15 acc. to DIN 17210
	1.4408	GX5CrNiMo19-11-2 acc. to DIN EN 10213-4

Due to our experience, we recommend to apply an electric welding process.

Because of the different material compositions and wall thickness of the steam traps and the pipe gas welding shall not be applied. Quenching cracks and coarse grain structure may develop.

On bimetallic steam traps face-to-face of 95 mm or less, the bimetallic controller has to be disassembled prior to welding. After the traps have cooled down to the ambient temperature the bimetallic controller shall be fitted again into the body.

Steam traps with socket-weld ends shall only be welded by arc welding (welding process 111 acc. to DIN EN 24063).

If during the time of warranty others than the manufacturer or by the manufacturer authorized persons are interfering in the product and/or the setting, the right of claim for warranty will lapse!

**Standard-flange dimensions**

Flanges according to DIN 2501

DN		(mm)	15	20	25	32	40	50	65	80	100	125	150	200	250
PN16	ØD	(mm)	95	105	115	140	150	165	185	200	220	250	285	340	405
PN16	ØK	(mm)	65	75	85	100	110	125	145	160	180	210	240	295	355
PN16	n x Ød	(mm)	4 x 14	4 x 14	4 x 14	4 x 18	4 x 18	4 x 18	4 x 18	8 x 18	8 x 18	8 x 18	8 x 22	12 x 22	12 x 26
PN40	ØD	(mm)	95	105	115	140	150	165	185	200	235	270	300	375	450
PN40	ØK	(mm)	65	75	85	100	110	125	145	160	190	220	250	320	385
PN40	n x Ød	(mm)	4 x 14	4 x 14	4 x 14	4 x 18	4 x 18	4 x 18	8 x 18	8 x 18	8 x 22	8 x 18	8 x 22	12 x 30	12 x 33

Dimensions in mm resp. inch  
 Weights in kg  
 1 bar  $\hat{=}$  10<sup>5</sup> Pa  $\hat{=}$  0,1 MPa  
 Kvs in m<sup>3</sup>/h  
 1 bar  $\hat{=}$  14,5 psi  
 1 inch  $\hat{=}$  25,4 mm